

Dainolite



Custom Design



Table of Contents:

Inspiration	pg. 1 - 63
Canopies, Rods and Parts	pg. 64 - 67
Standard Fabric Selection	pg. 68 - 69

How do you catalogue imagination?

You don't! But you can try!

Following are 63 pages of inspiration, just a little help for the imagination.

Dainolite has been building custom lamp shades and shaded fixtures for over thirty years. We blend modern computerization with old world craftsmanship in our custom studio. CNC machines produce accurate execution of your ideas while time honoured craftspeople provide the attention to detail that a machine just cannot do.

Browse through our catalogue and be inspired.
Then contact Dainolite for your next illuminating project.

Tel: [905.564.1262](tel:905.564.1262)
Email: dainolite@dainolite.ca
Web: www.dainolite.ca

See our Contemporary Lighting Solutions Catalogue, LED Catalogue or Lamp Shade Catalogue for in-stock products.

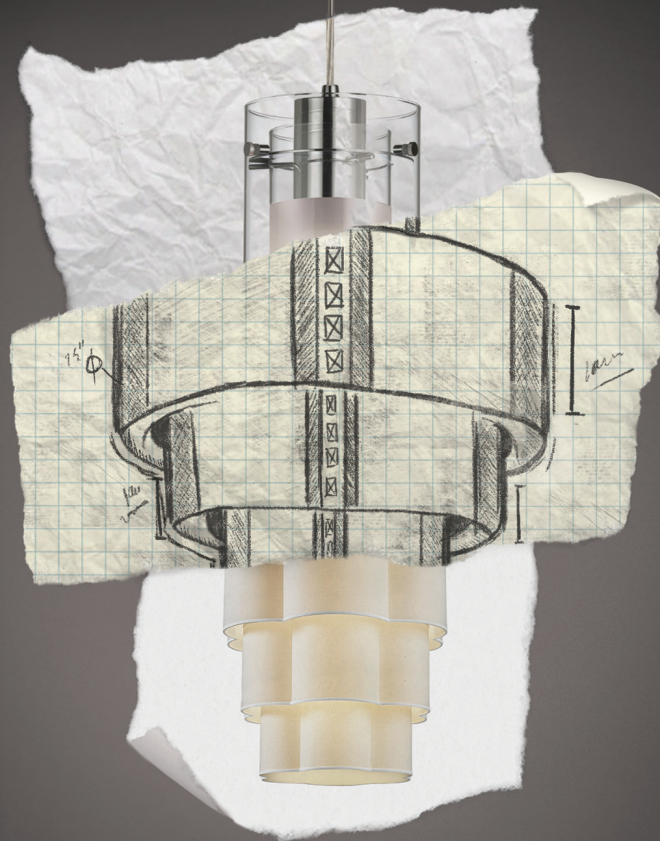

Bring your ideas together.

CREATE UNIQUE LIGHTING DESIGNS TO FIT ANY DECOR

dainolite.ca/customlighting | 1-888-564-1262



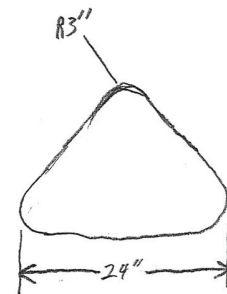
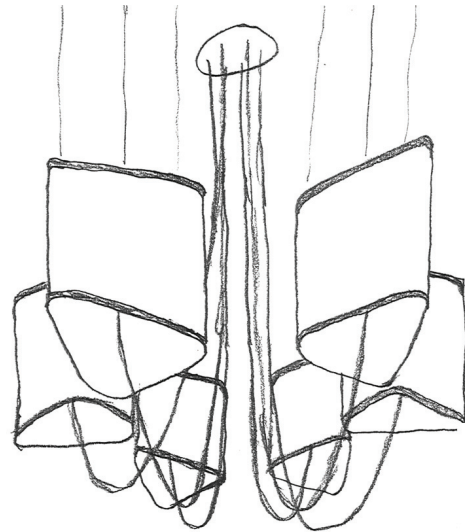

Top
(1 Shade)

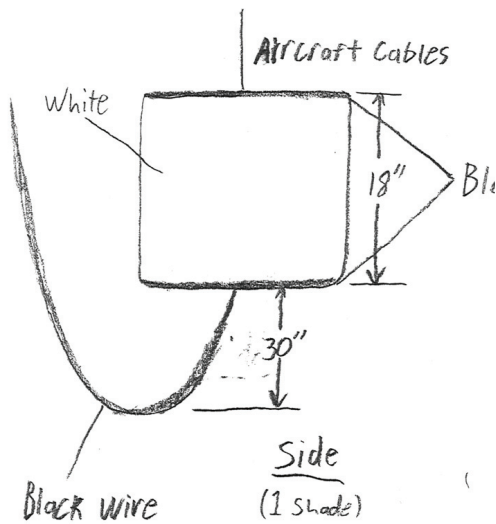

Aircraft Cables

White

18''

B₁

30''

Side

(1 Shade)

Black wire

Designer's Sketch

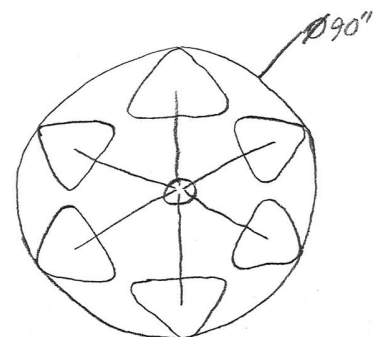

Bottom

CAD
Rendering

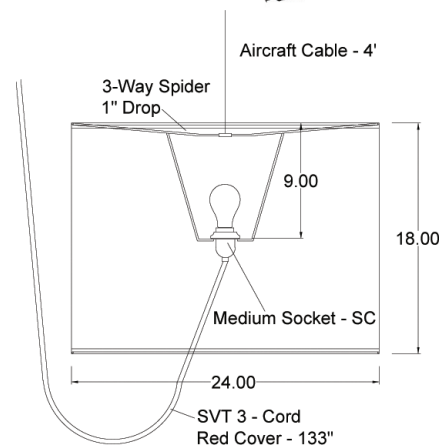
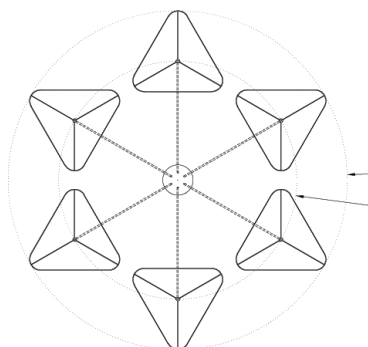

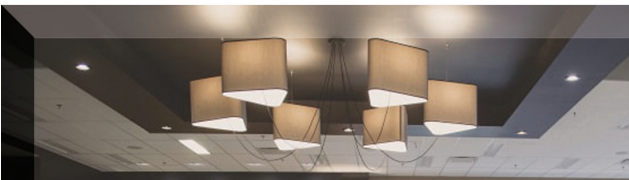



Designer's Sketch

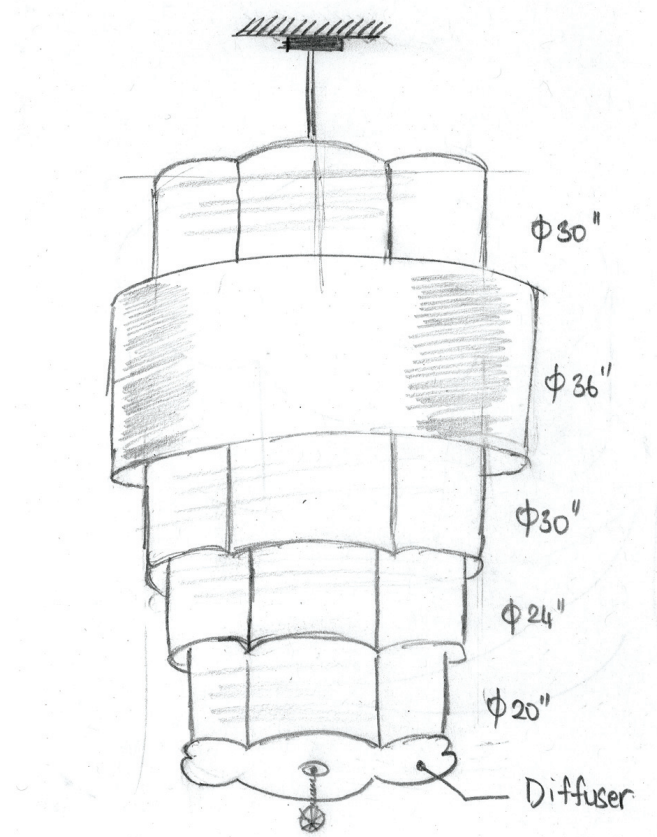

CAD Rendering

Front View

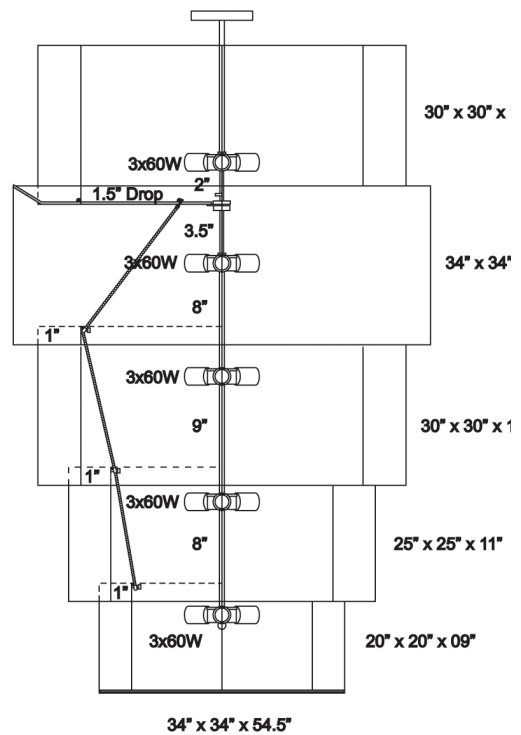

Top View

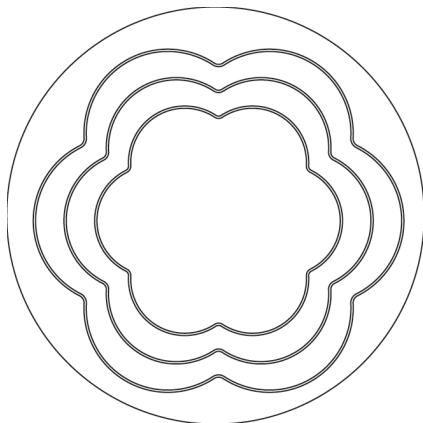

INTERMEZZO

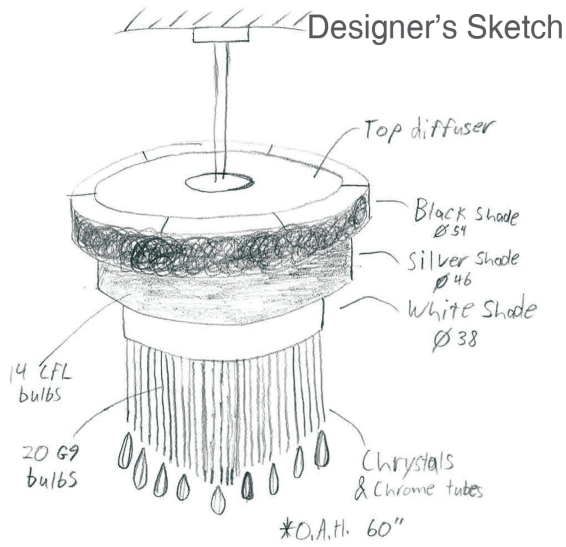

CAD Rendering

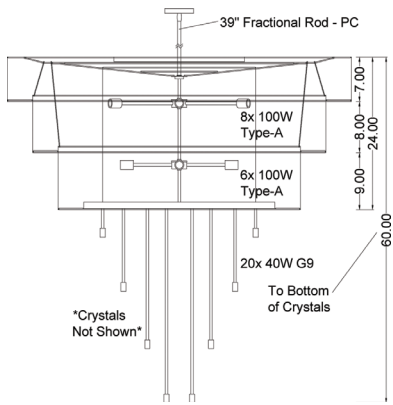

Front View

Top View

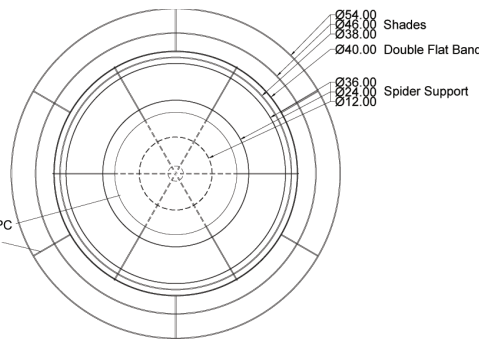

Canopy 20" - PC
 Frame Painted Silver



CUSTOM DESIGNS



Hardback shades cap a beautiful hand sewn softback diffuser.

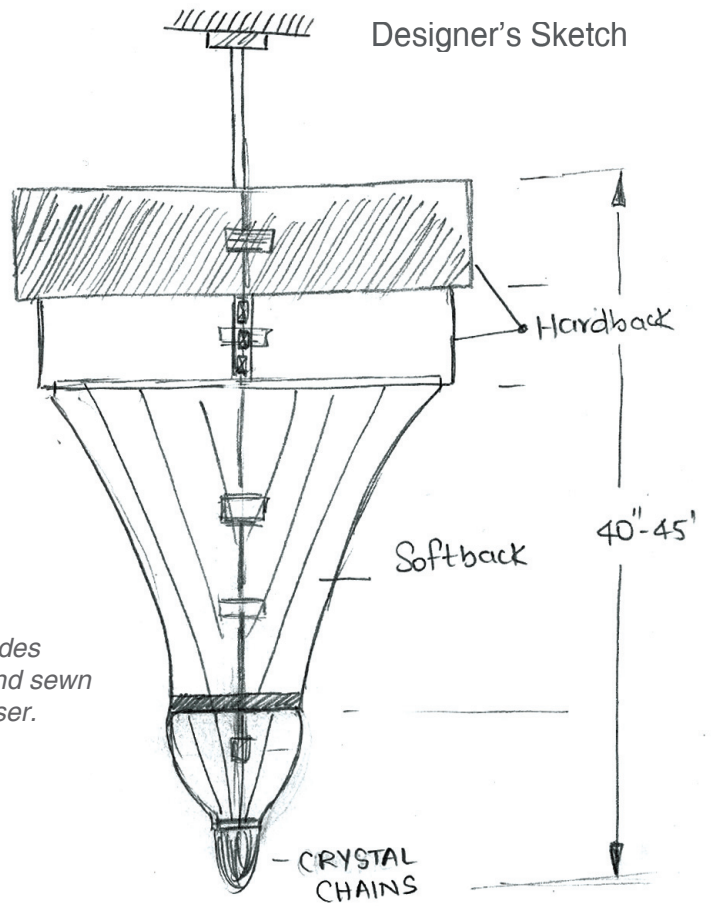

CAD Rendering

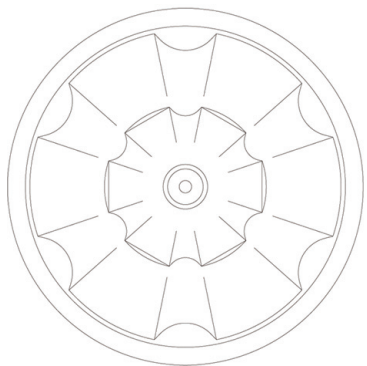
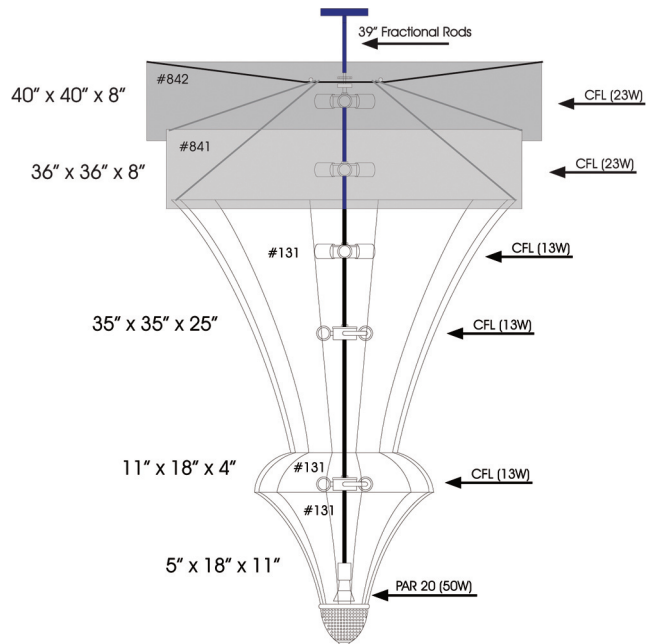

40" x 40" x 60"

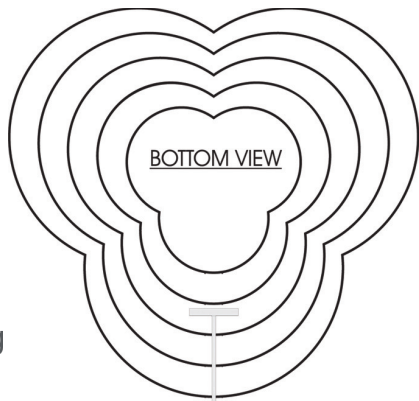
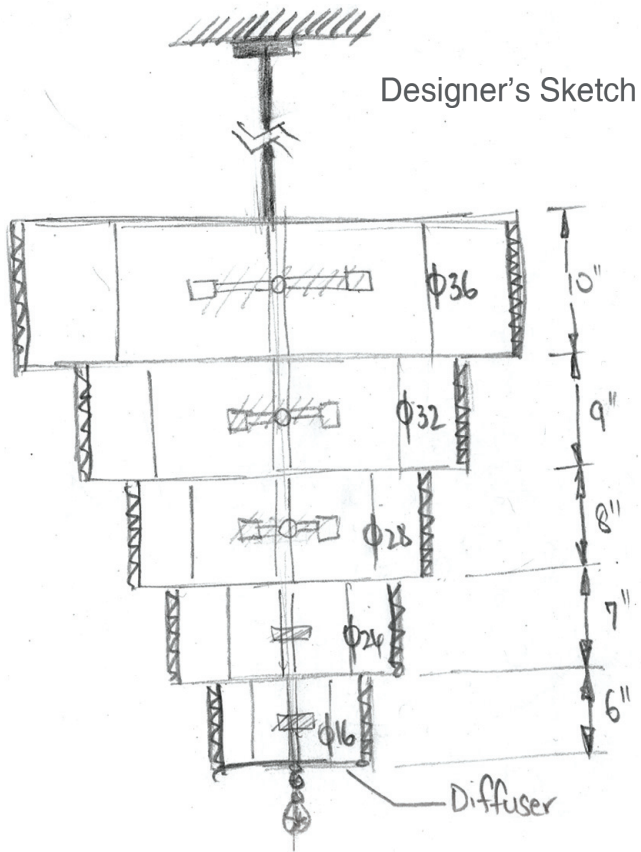

CAD Rendering

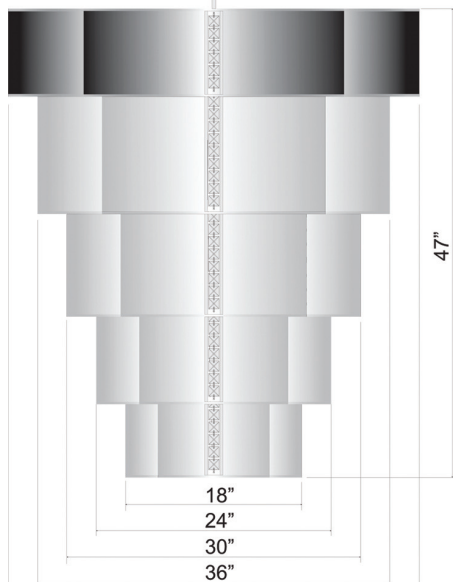

Designer's Sketch

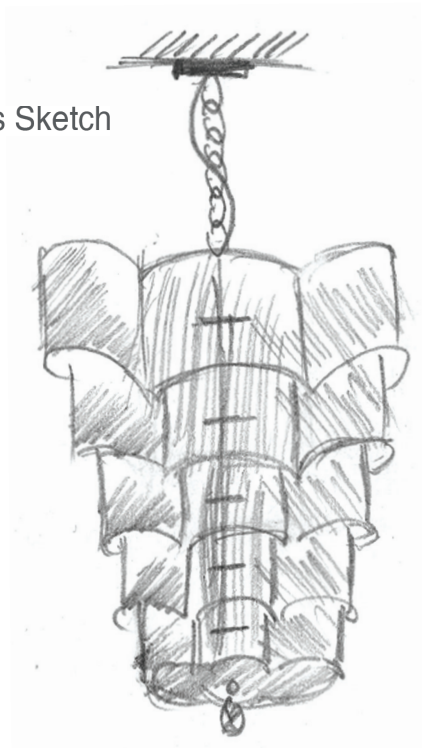

Designer's Sketch

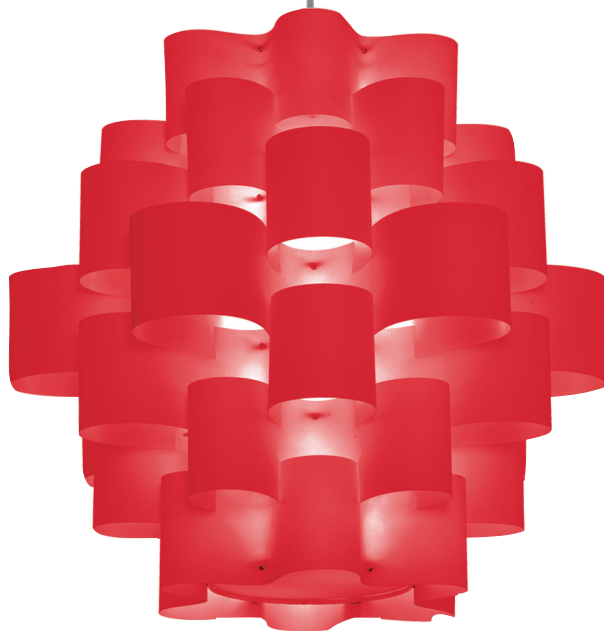
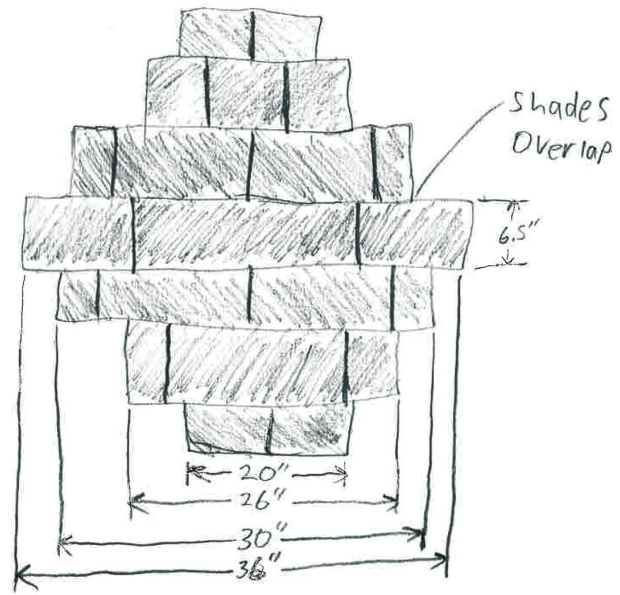

CAD Rendering

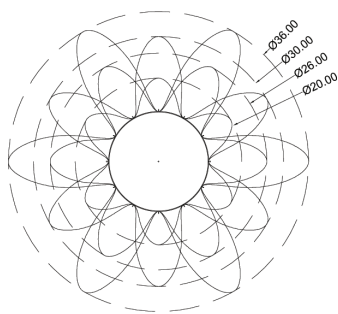
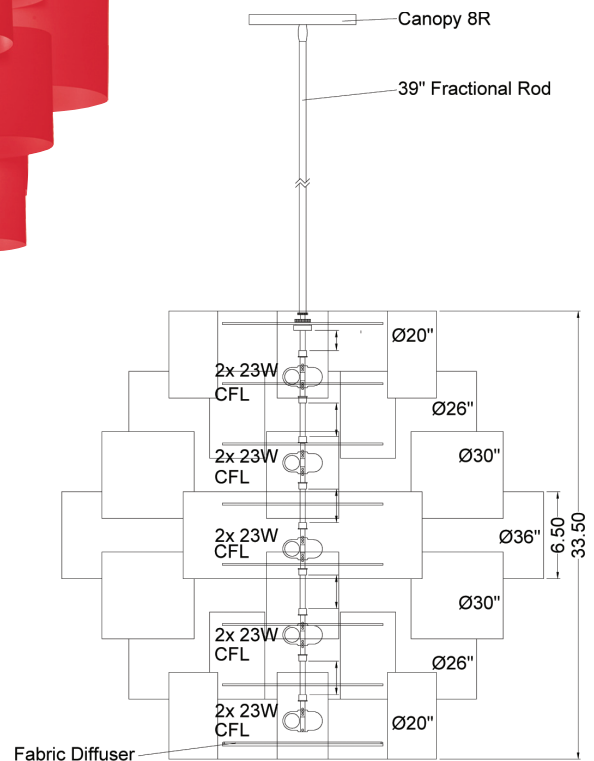

Bottom View

Side View



Designer's Sketch

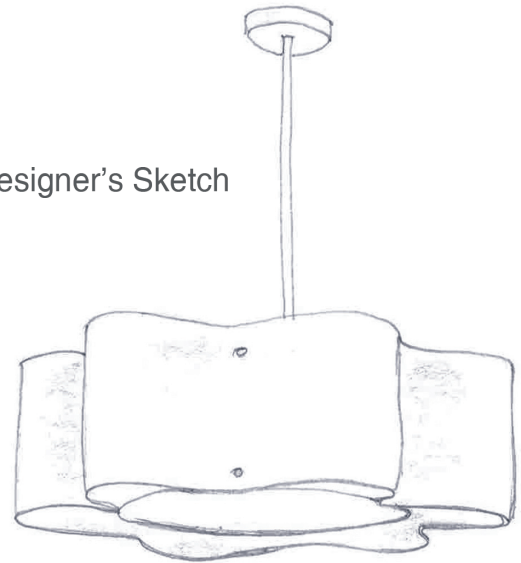

CAD Rendering

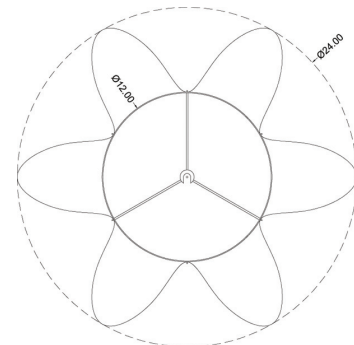
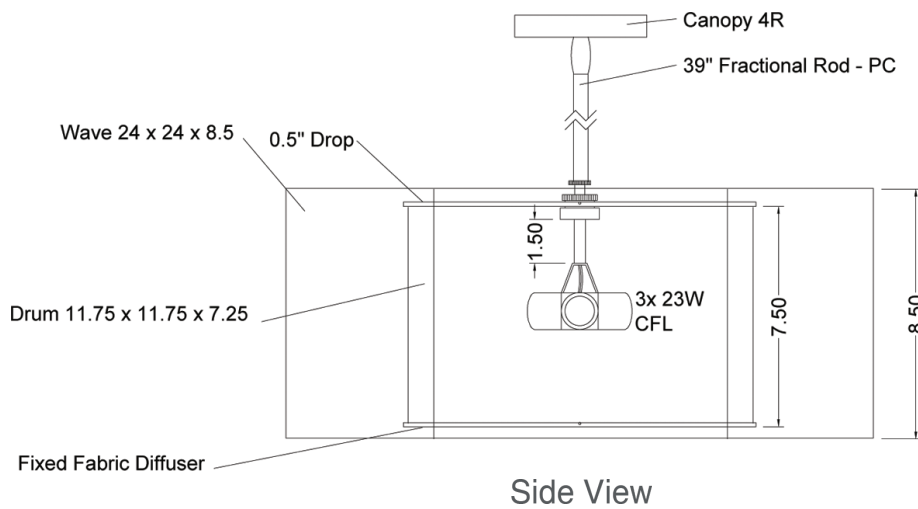

CAD
Rendering

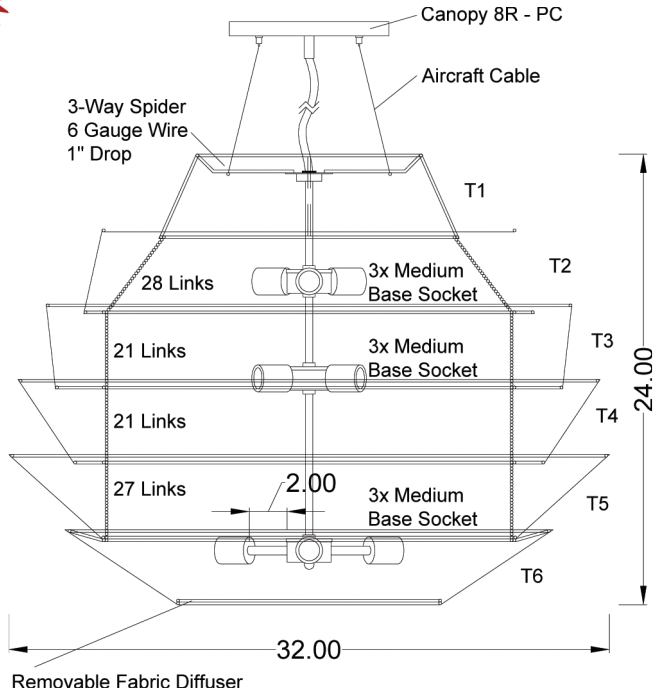

Designer's Sketch

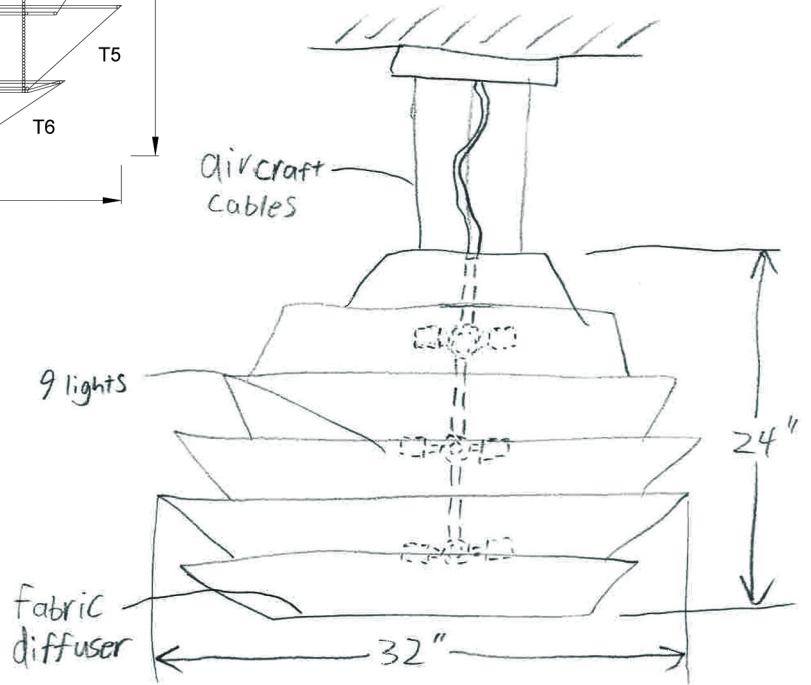

CUSTOM DESIGNS

Designer's Sketch

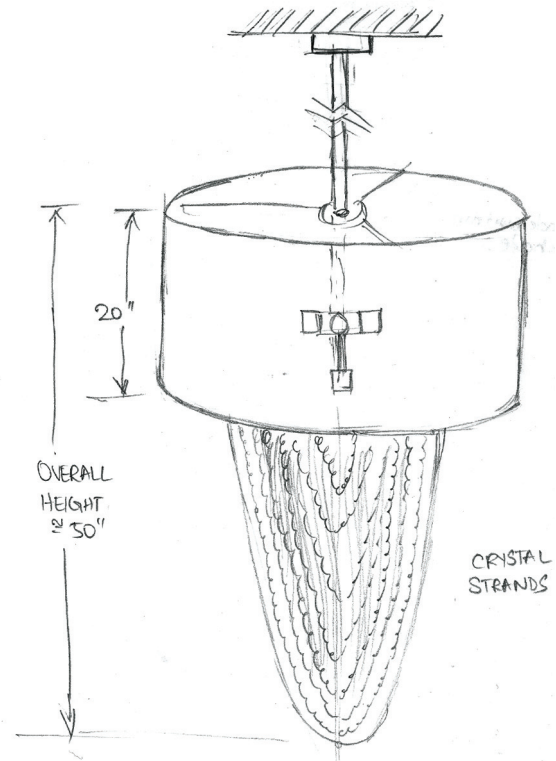

CAD Rendering

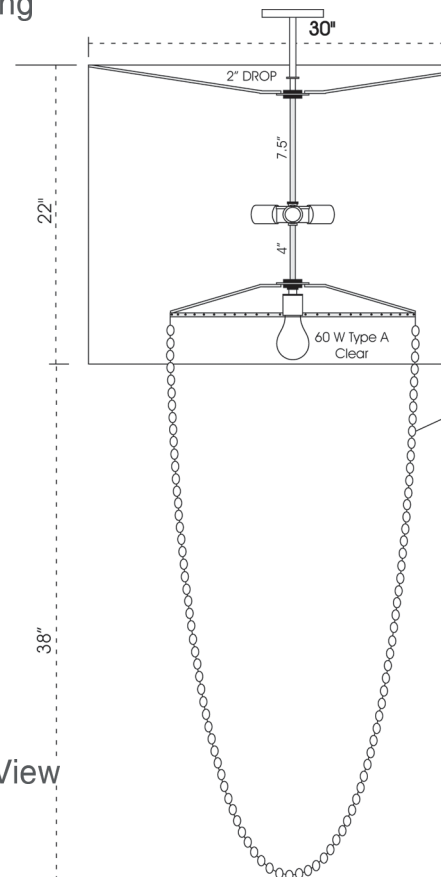

*Sequined hardback fabric
dazzled in Niagara Falls
Casino setting*

Front View



CAD
Rendering

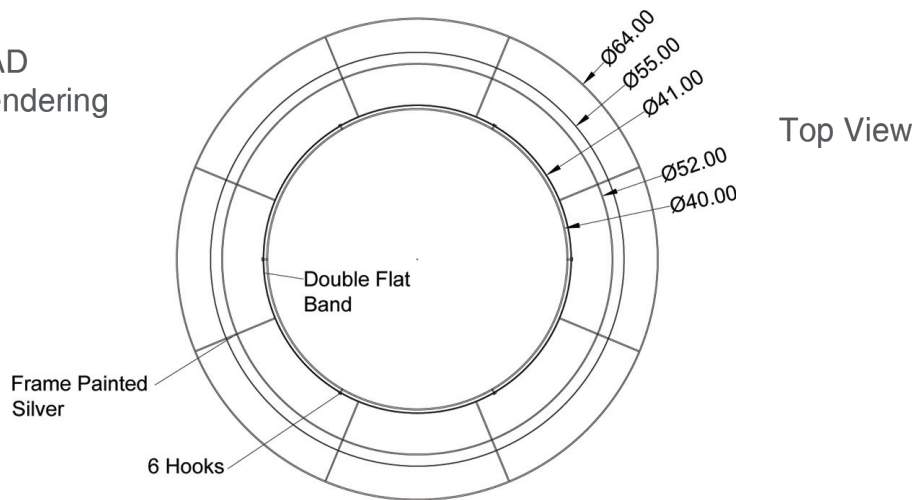

Side View

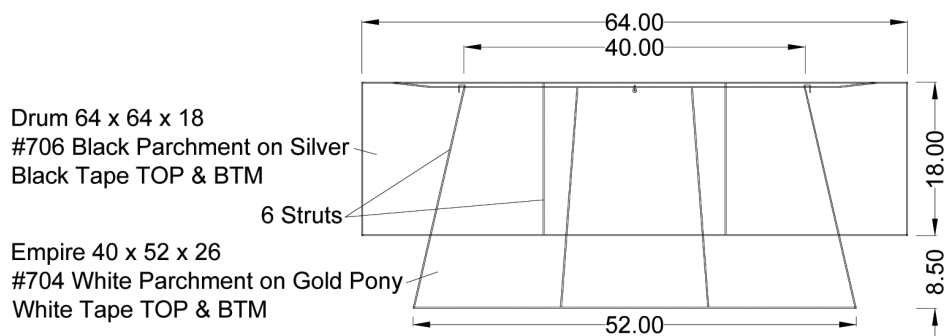



Designer's Sketch

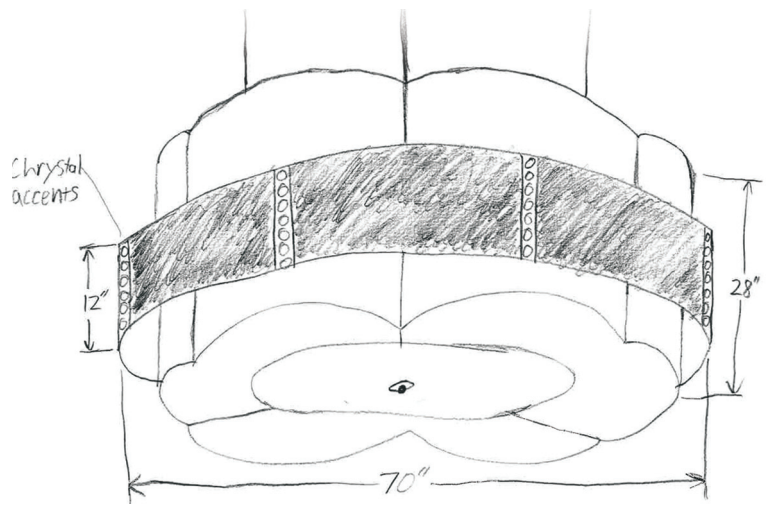

CAD Rendering

Top View

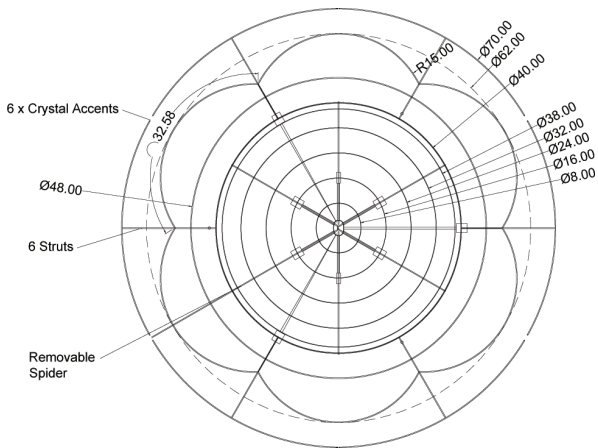

Front View

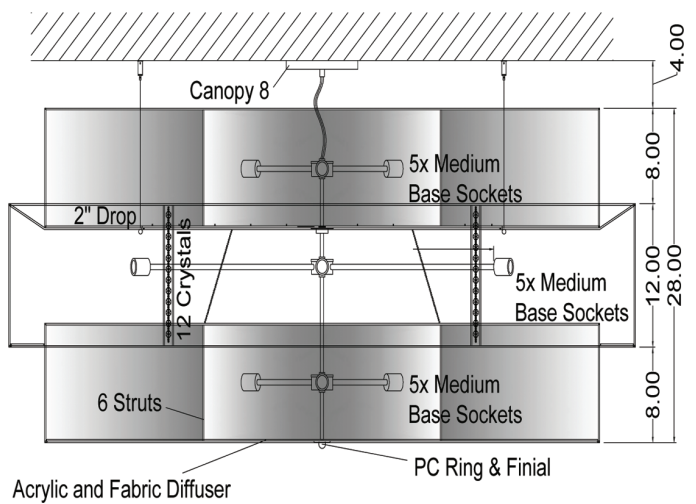



Designer's Sketch

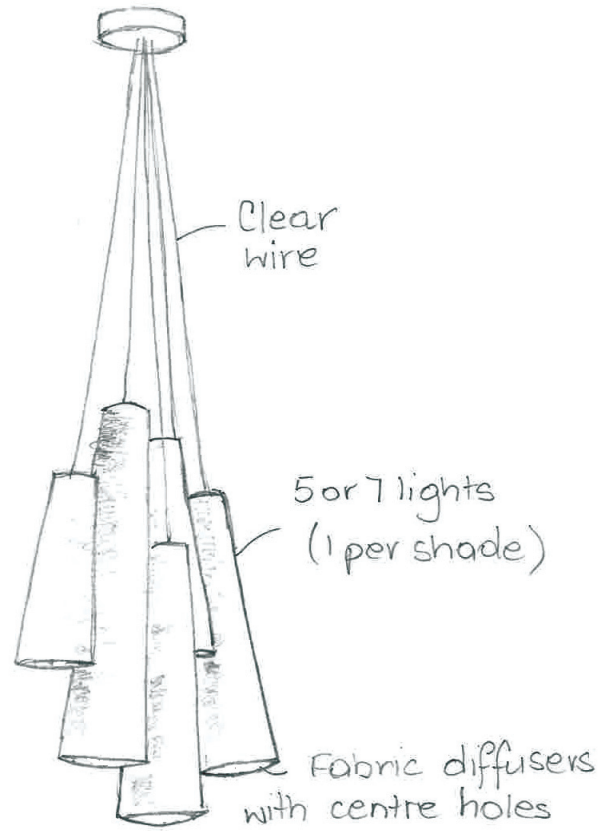

CUSTOM DESIGNS

CAD Rendering

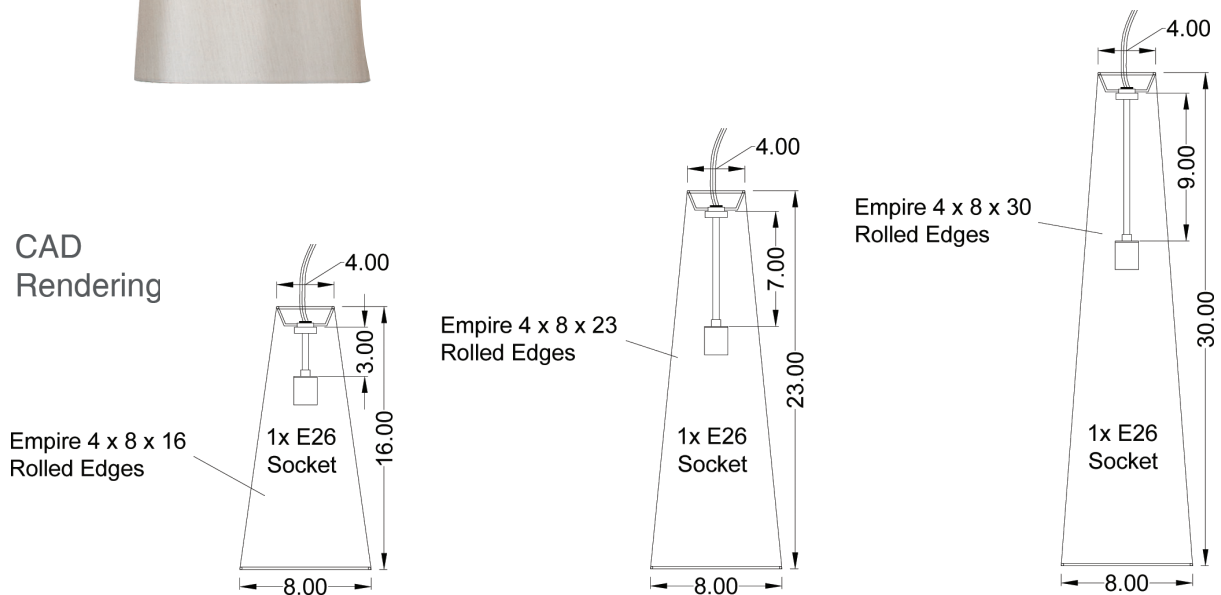

GLOBUS



DBLV-790-WH



DBL-L-790

Designed in the 70's and replicated for decades; a single fabric element can be made any size and used in multiple ways to create interesting and provocative designs.



DBL-3SR-790



DBL-S-790



DBL-S-795



DBL-M-795



DBL-FLT-790

CUSTOM DESIGNS

Designer's Sketch

CNC wire machines enable Dainolite to sculpt almost any shape from wire. Stretch Lycra fabric over the wire and Voila!



CAD Rendering

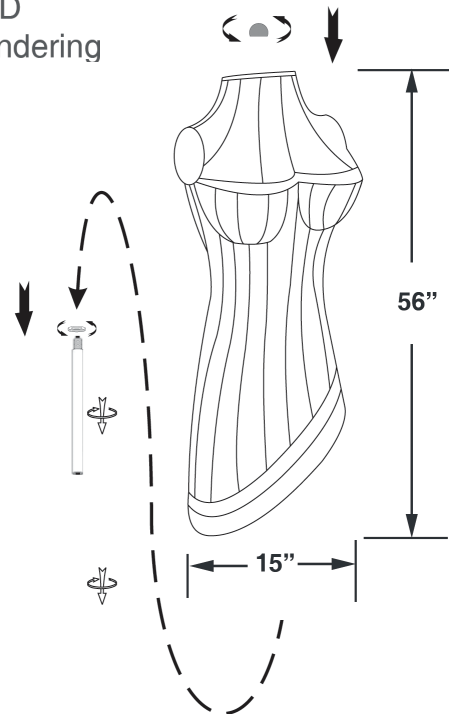

BULB/AMPOULE
Max 50W GU10 120V
(not included/non include)



STAIRS TO NOWHERE - BIG BROTHER TV SHOW

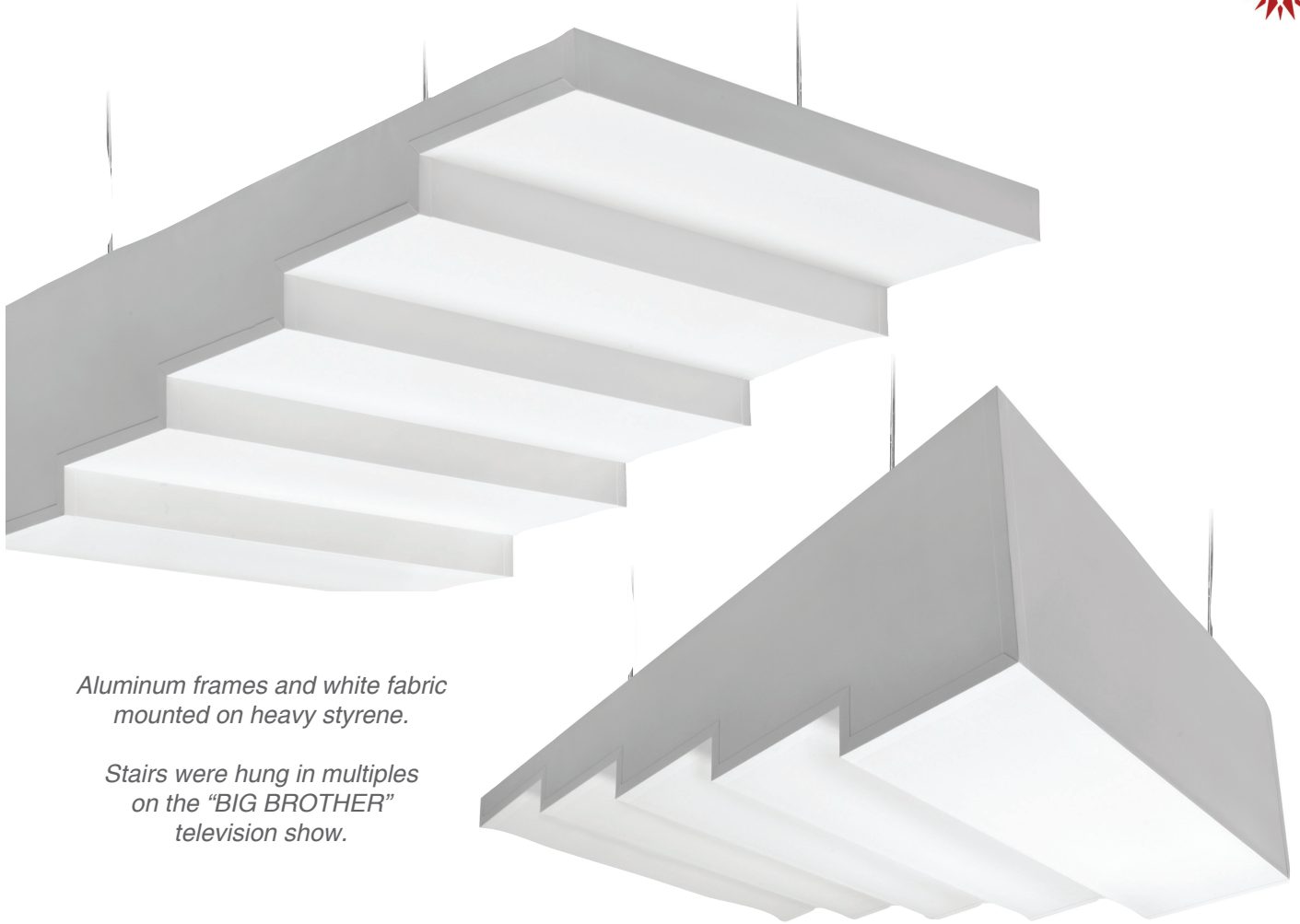

Aluminum frames and white fabric mounted on heavy styrene.

Stairs were hung in multiples on the "BIG BROTHER" television show.

CAD Rendering

Top View

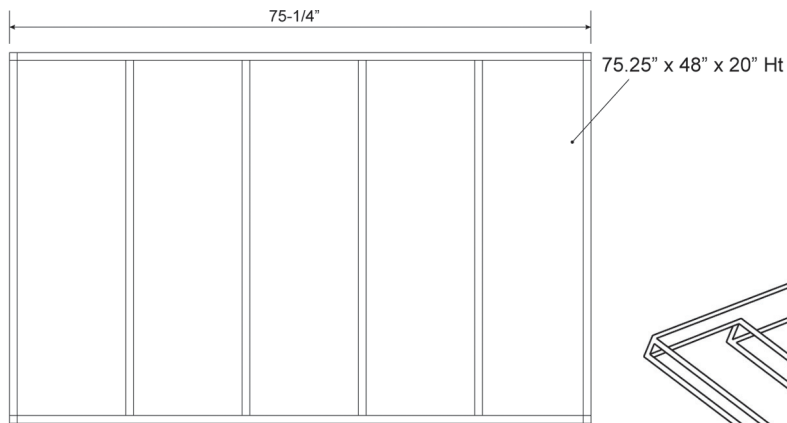

3D View

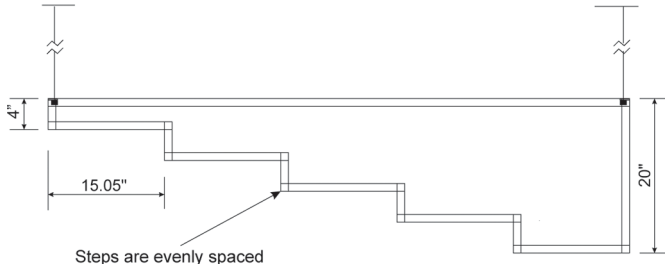
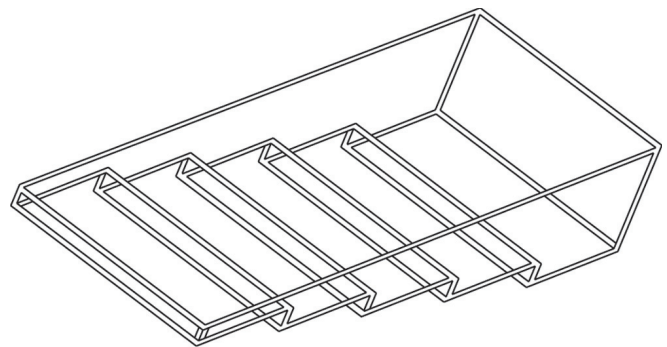

Front View

CUSTOM DESIGNS

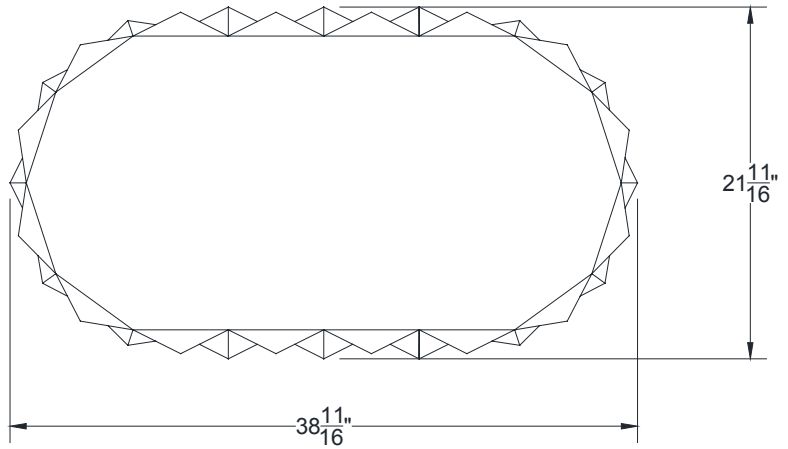
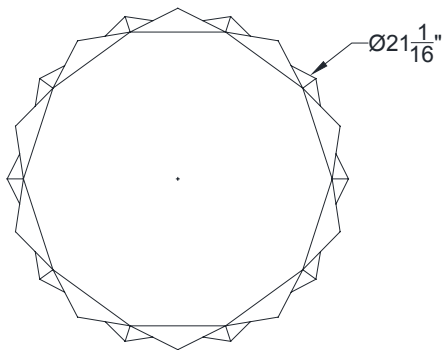

CUSTOM DESIGNS

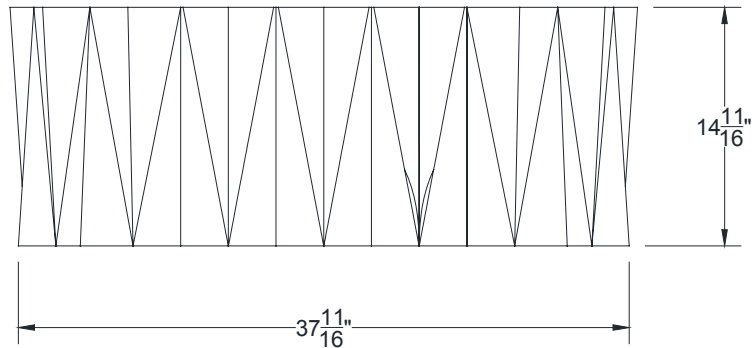
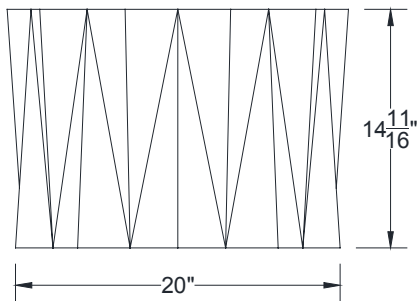



Designer's Sketch

Six foot HALO encloses a PL fixture.

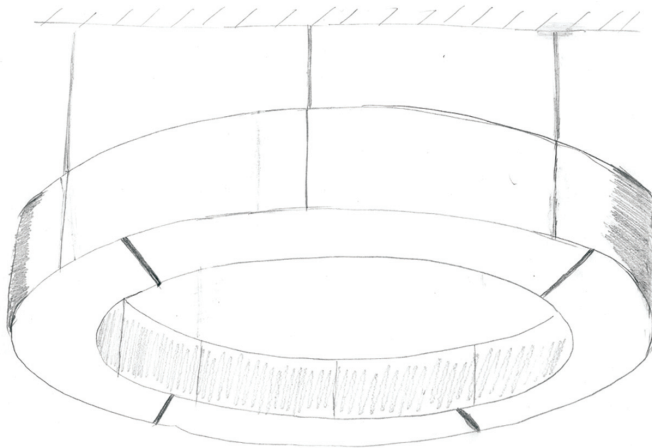

CAD Rendering

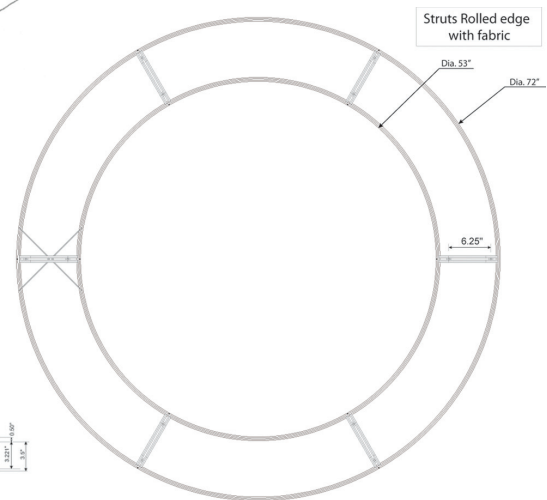

Top View



Front View



CAD Rendering

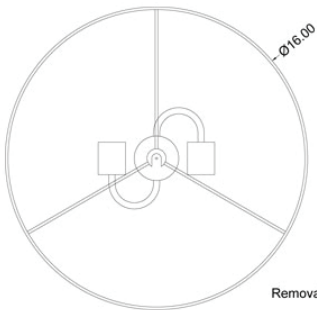

Removable Acrylic Diffuser

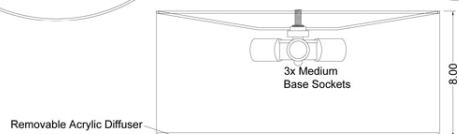
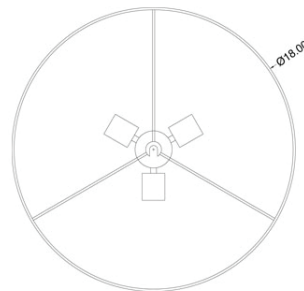
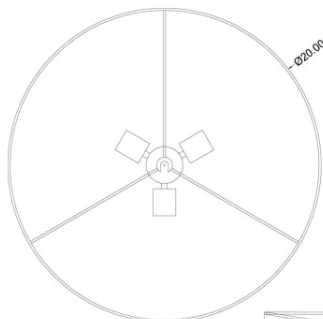
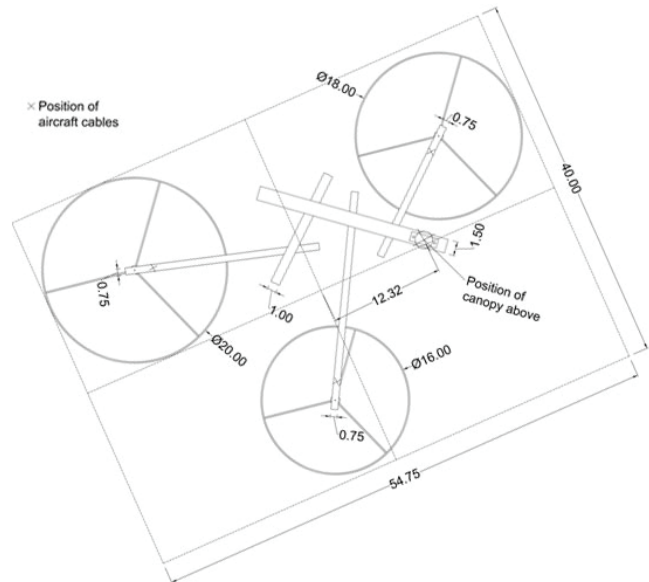
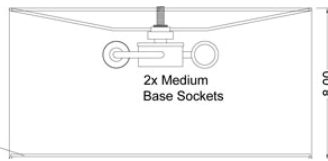

CUSTOM DESIGNS

OTHER SPECIAL DESIGNS



SURVEILLANCE FIXTURE

Creative way to introduce security into a lobby or business area

Designer's Sketch

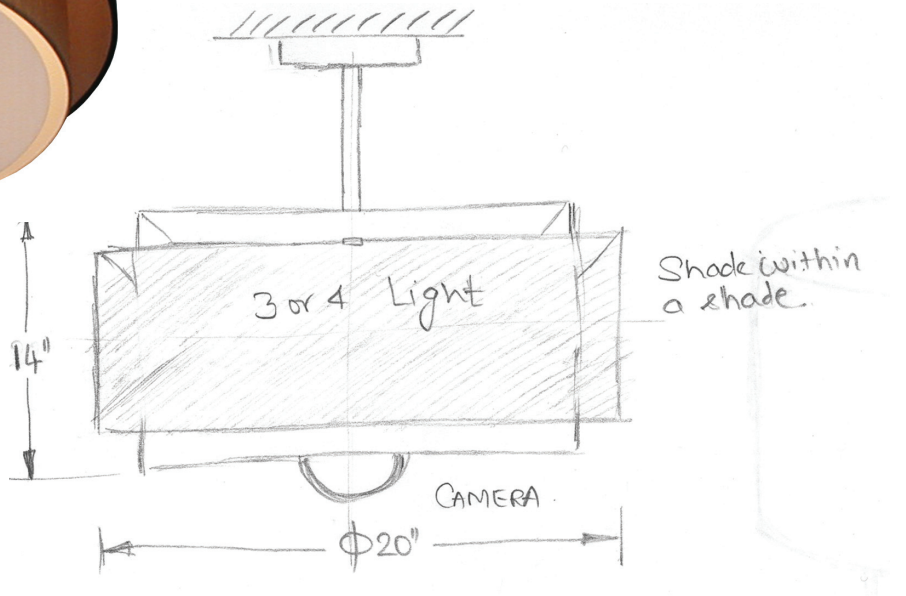

OVERSIZED WALL LIGHT
571412-790-CC20



HOMWOOD SUITES WALL LIGHT



CUSTOM DESIGNS

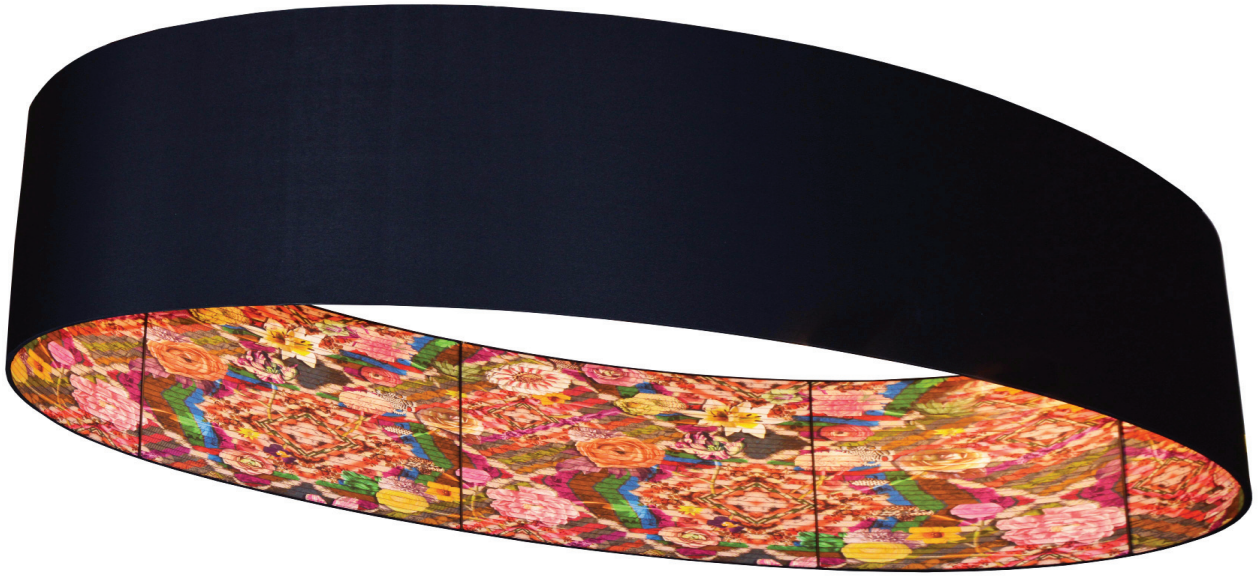

MUSKOKA SHADES



CUSTOM DESIGNS



FABRICS



AYTEL SHADE



TILDA SHADE



AMOUR SHADE



CUSTOM DESIGNS

CUSTOMER'S OWN MATERIAL (COM)



WOOD GRAIN



CUSTOMER'S OWN MATERIAL (COM)



FABRIC CUT OUTS



HGTV
INCOME PROPERTY SHOW



CUSTOM DESIGNS

Service Centre or Kiosk fixture.
Shipped flat and assembled on site.

Designer's Sketch

Cut Out Letters

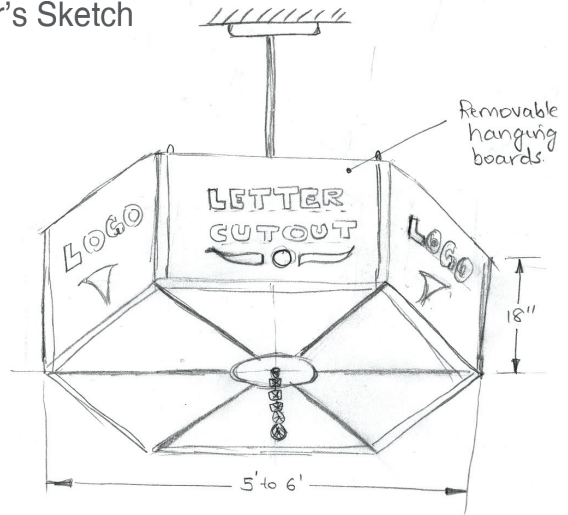
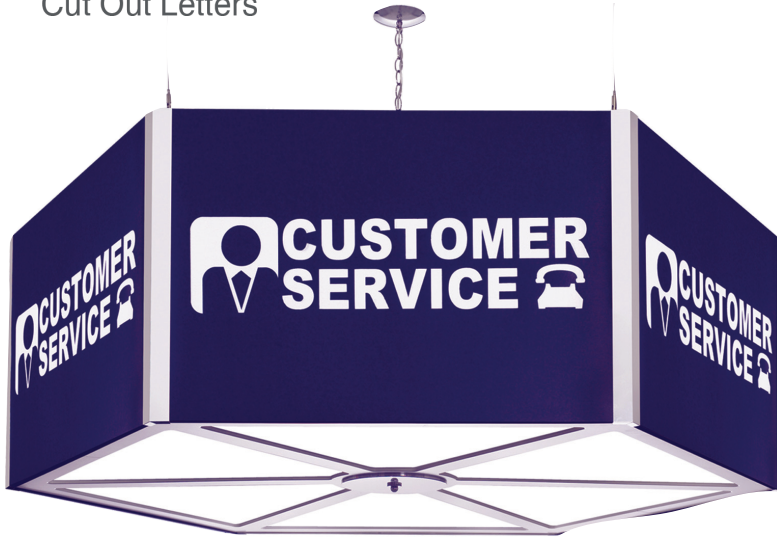

CUSTOM DESIGNS

FABRIC CUT OUTS with CRYSTAL

RHIANNON
CRYSTAL ACCENTS



Designer's Sketch

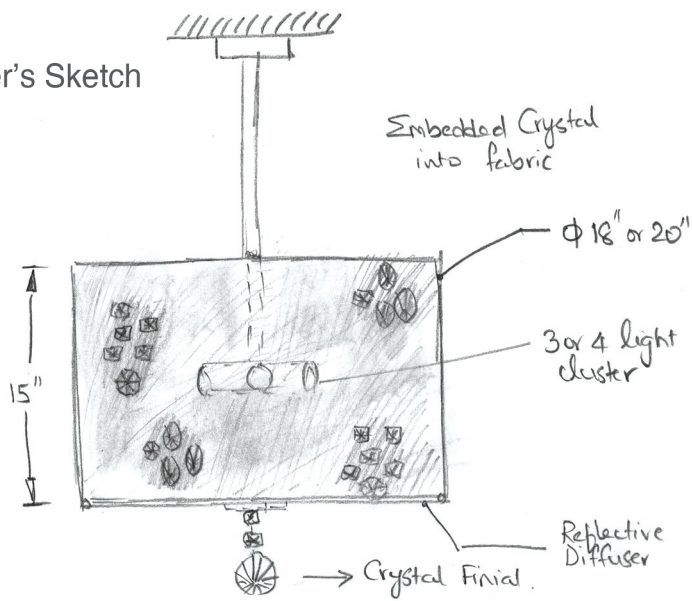

Patterns



CAD Rendering

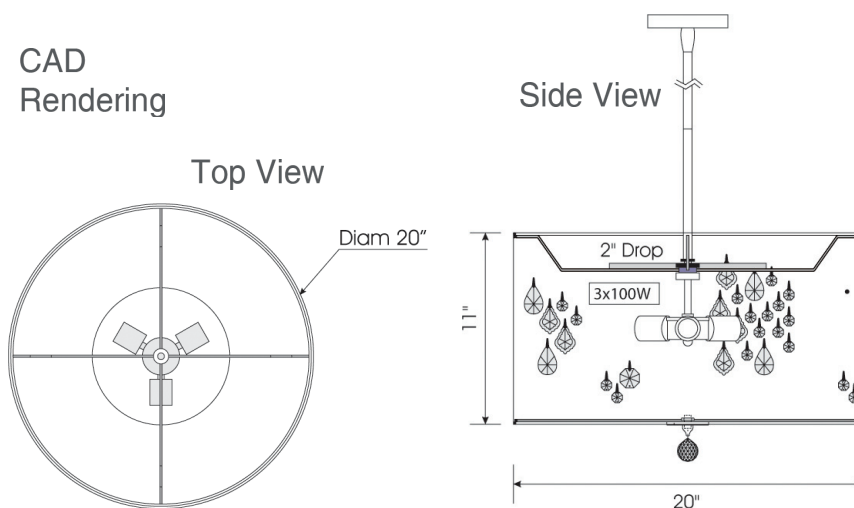

CUSTOM DESIGNS

RIBBON WRAP



Over seven hundred feet of 1" satin ribbon was carefully layered and hand sewn to create these stunning shades

Designer's Sketch

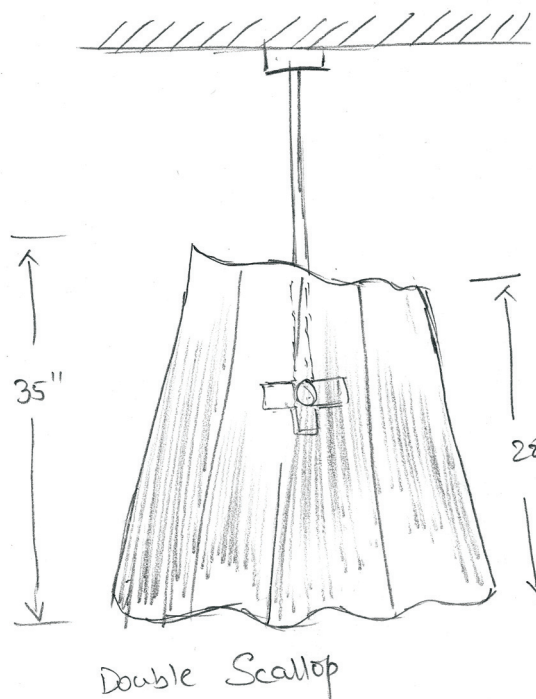

CAD Rendering

RIBBON WOVEN DRUM

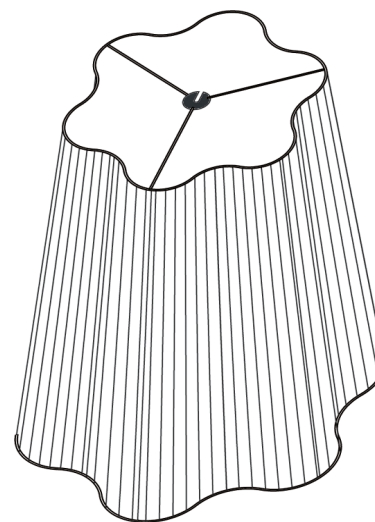



ROSEWOOD



WHITE OAK



ZEBRAWOOD



ACRYLIC BACKER



METAL BANDING



**“REVEAL” option
JASMINE**



**DRUM SHADED FIXTURE
ANY DIAMETER and HEIGHT**



CUSTOM DESIGNS

LIGHTS at FERNHILL



CUSTOM DESIGNS



BOULEVARD CLUB - Toronto

Large Organza shades were retrofitted to enhance these 40's vintage Williamsburg chandeliers. Shades were dropped over the fixtures on site without lowering or disconnecting the fixtures.



Top/Front View

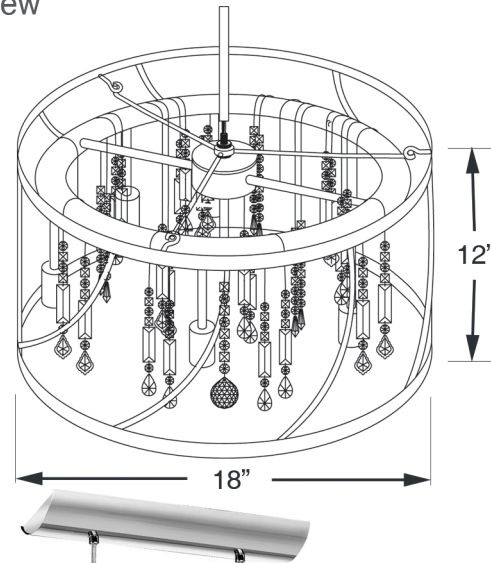

Hand sewn organza fabric stretched over whimsical wire frames.

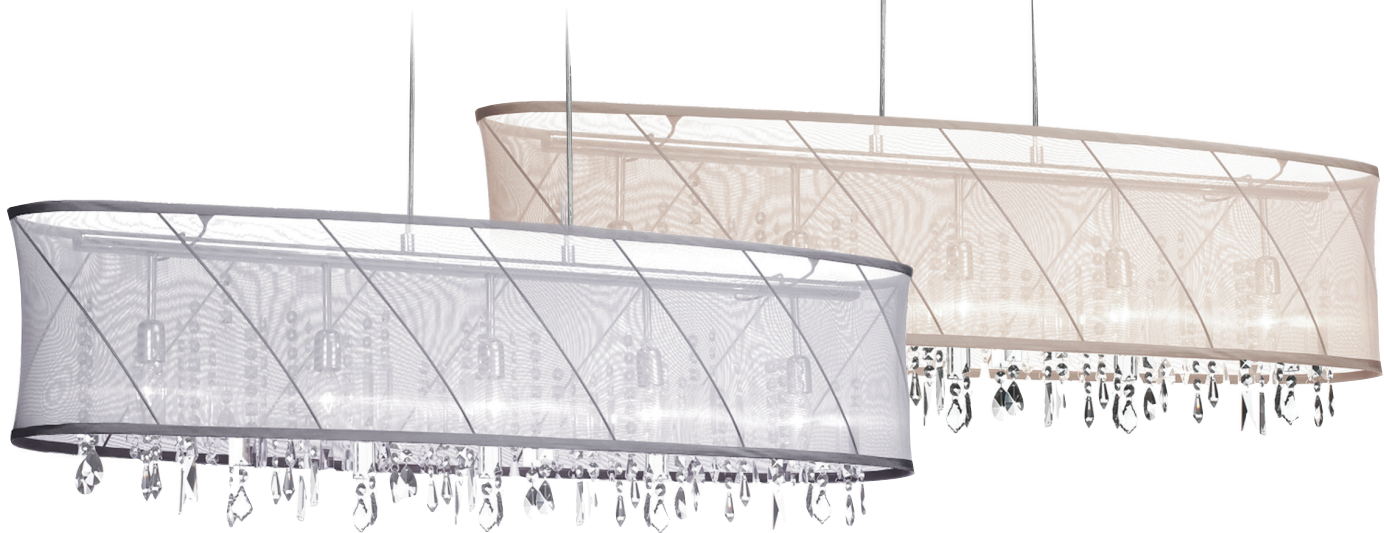

CAD Rendering

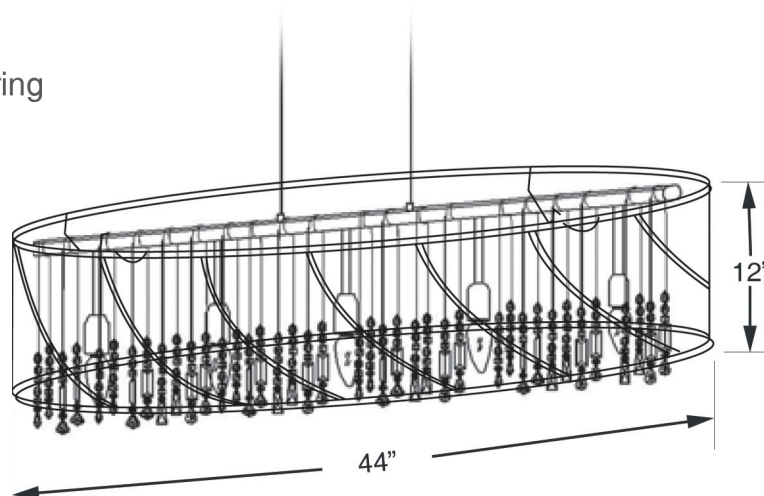

TIERED DRUMS



ELISE



Designer's Sketch

Add crystal to any hardback application for some more drama or sophistication.

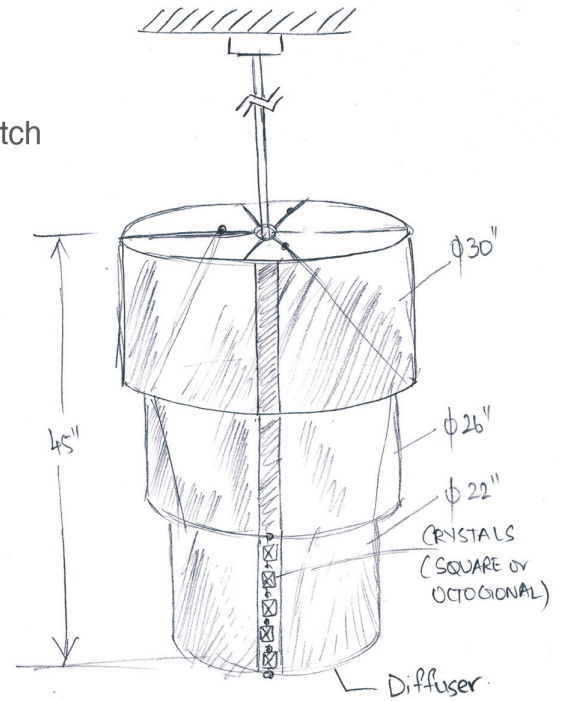

CAD Rendering

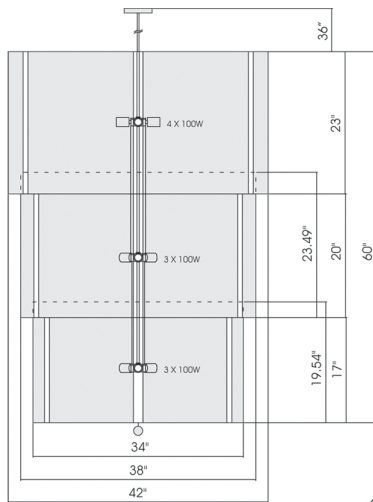

Front View

Top View

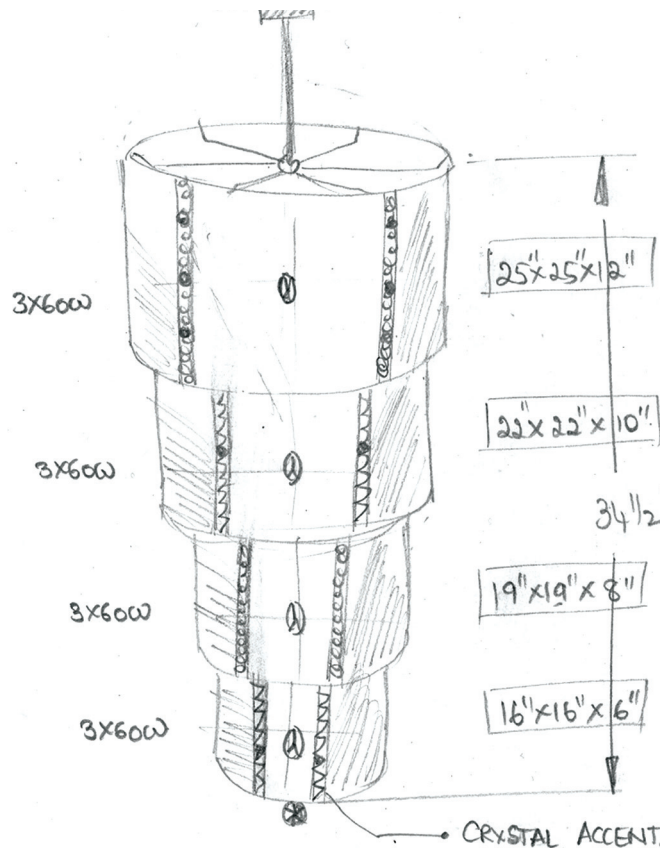
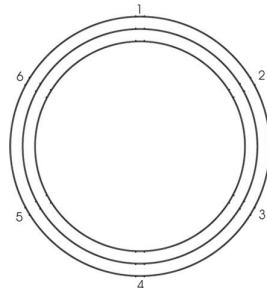

CUSTOM DESIGNS

TIERED DRUMS

One tier, two tier, three tier or more.
Drum shaded fixtures any diameter
and height.

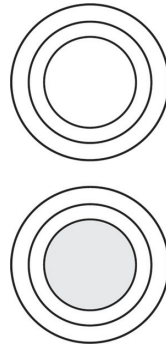
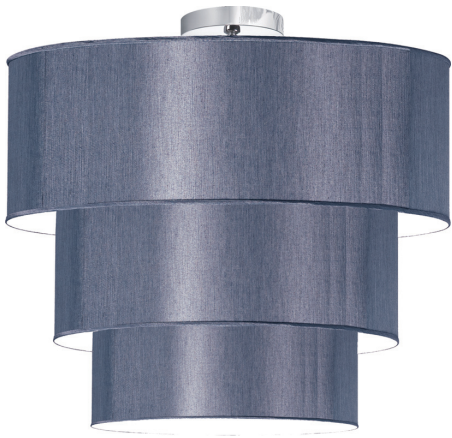

723017S-772-PC

Designer's Sketch

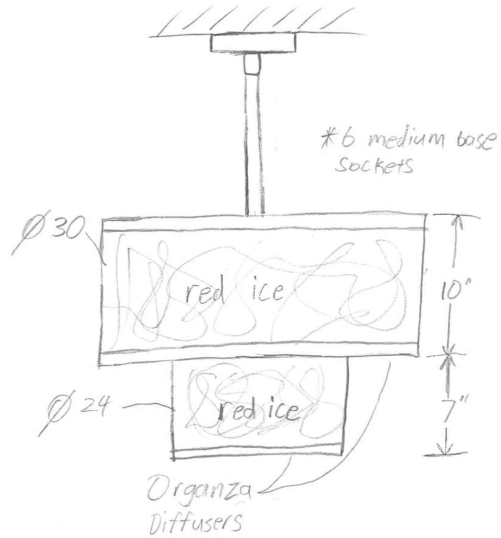

97-362326-SP-815
TWO PENNY SHADE



CUSTOM DESIGNS

TIERED DRUMS

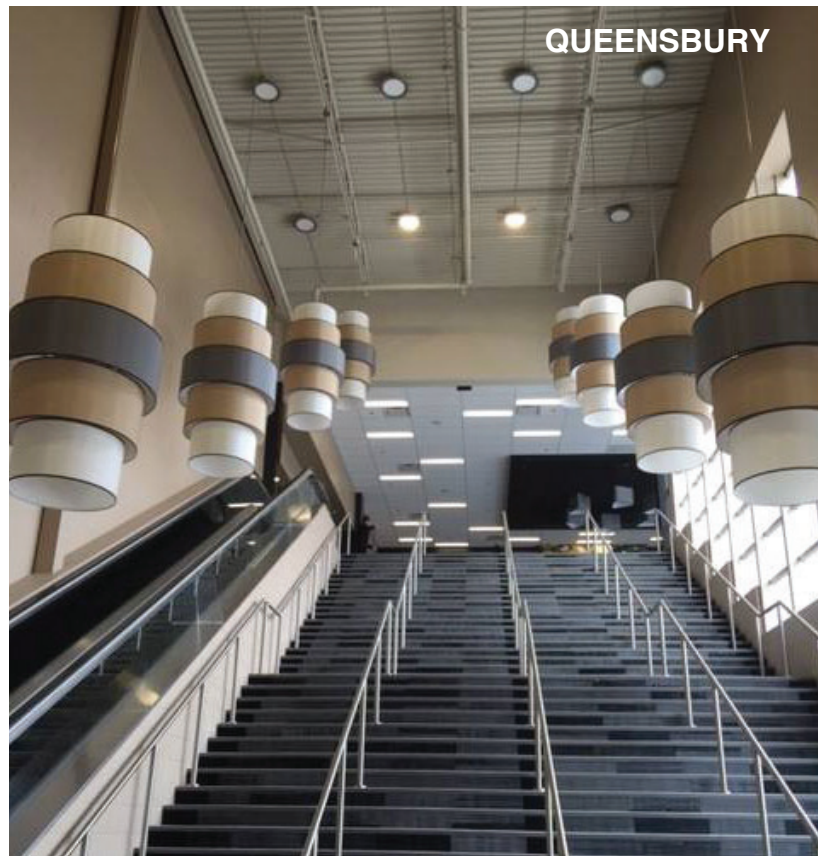

CUSTOM DESIGNS



TURTLE JACK'S - TORONTO



*Elise 3 tier drums,
Rectangular Organza
Crystal Chandeliers
and Tiny Suede
Mini Pendant
add drama and character
to this contemporary
restaurant.*

RITA



Chic Art Deco

PENDANT

Designer's Sketch

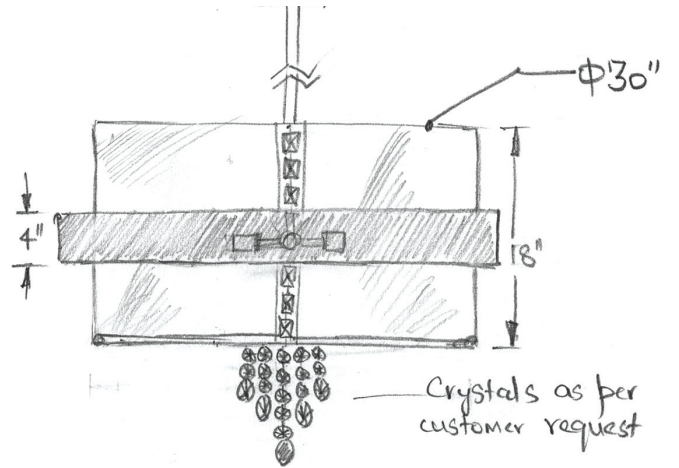

WALL SCONCE

Designer's Sketch

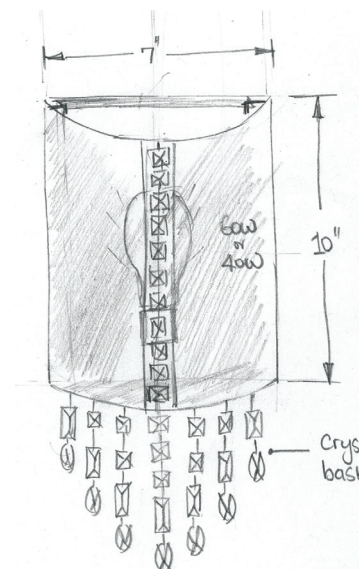

CUSTOM DESIGNS

AGAINST THE GRAIN - TORONTO



SHADE WITHIN A SHADE



MELISSA



WALL SCONCE



DRUM



Linen and Organza combination



CUSTOM DESIGNS

MING ROOM - MISSISSAUGA

MELISSA
"Shade with a Shade"
fixture



CHICAGO FIRE CLUB HOUSE



Top View

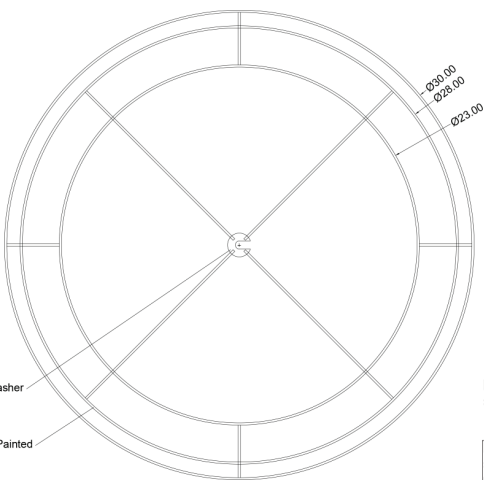

CAD Rendering

Front View

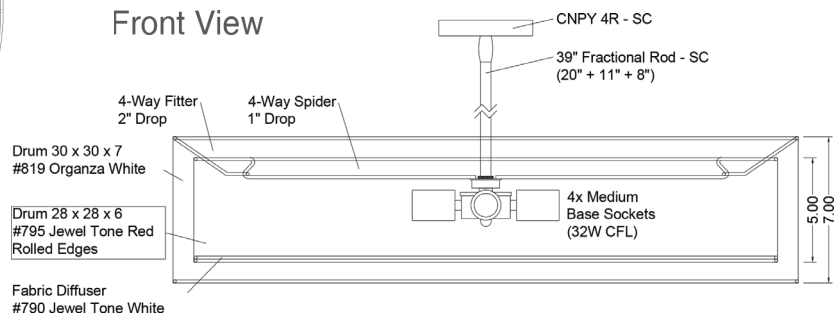

CUSTOM DESIGNS

Oval shaded fixtures
Any size and material.

PLAIN OVAL



TIERED ICE



CUSTOM DESIGNS

OVERSIZED
Shade size: L74" x D36" x H26"

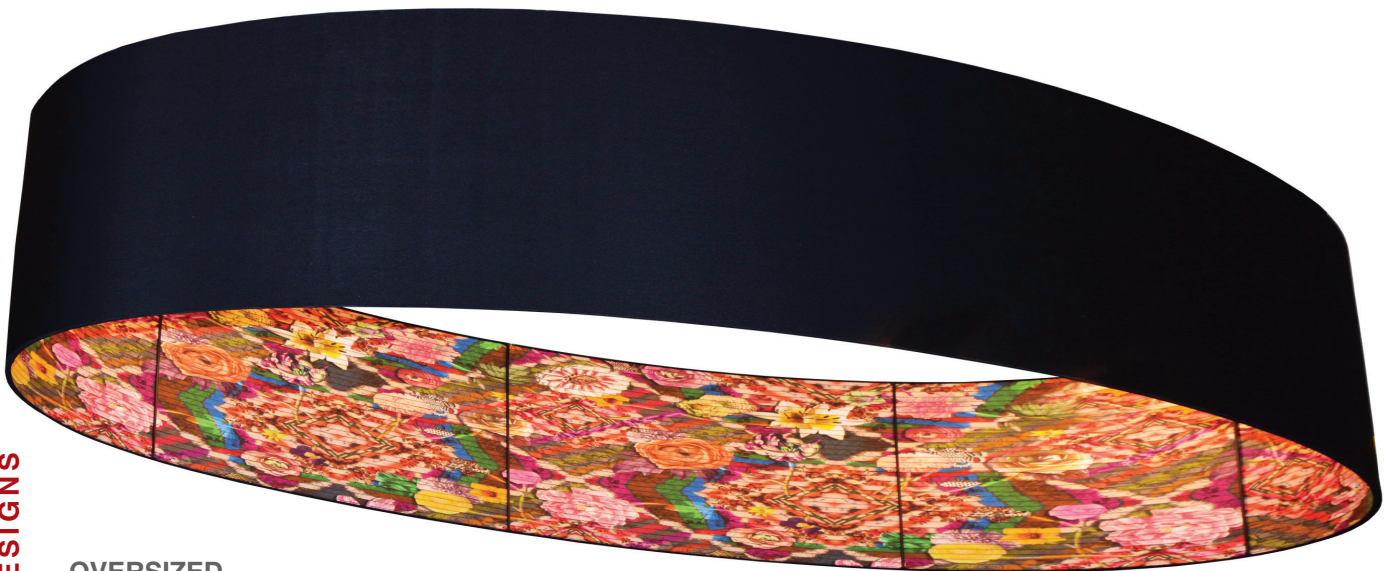

SQUARES

PLAIN SQUARE



*Square shaded fixtures
any size and fabric.*

SQUARE WITH
CRYSTAL ACCENTS



SQUARE WITH
FABRIC DIFFUSER



SQUARE WITH
ACRYLIC DIFFUSER





CAD
Rendering

CUSTOM DESIGNS

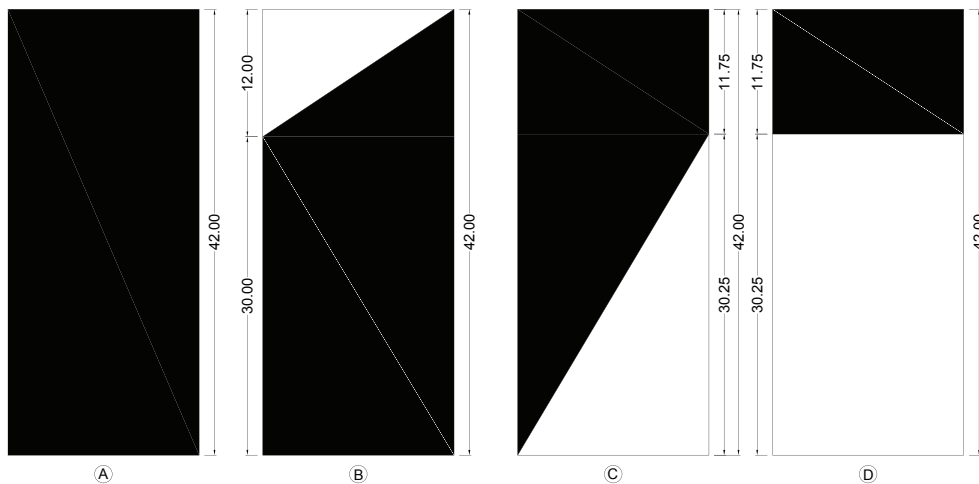

TIERED SQUARES



GREY WOOD GRAIN

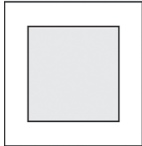
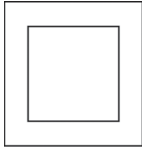

*One tier, two tier, three tier or more.
Drum shaded fixtures any diameter
and height.*

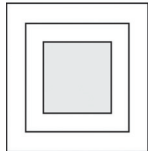
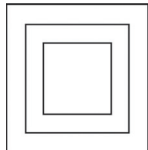

CUSTOM DESIGNS

UPPER VILLAGE - MARKHAM

Simple compound cubes waterfall their way down from the ceiling in this condominium's common area foyer.



RECTANGLES



9' RECTANGULAR

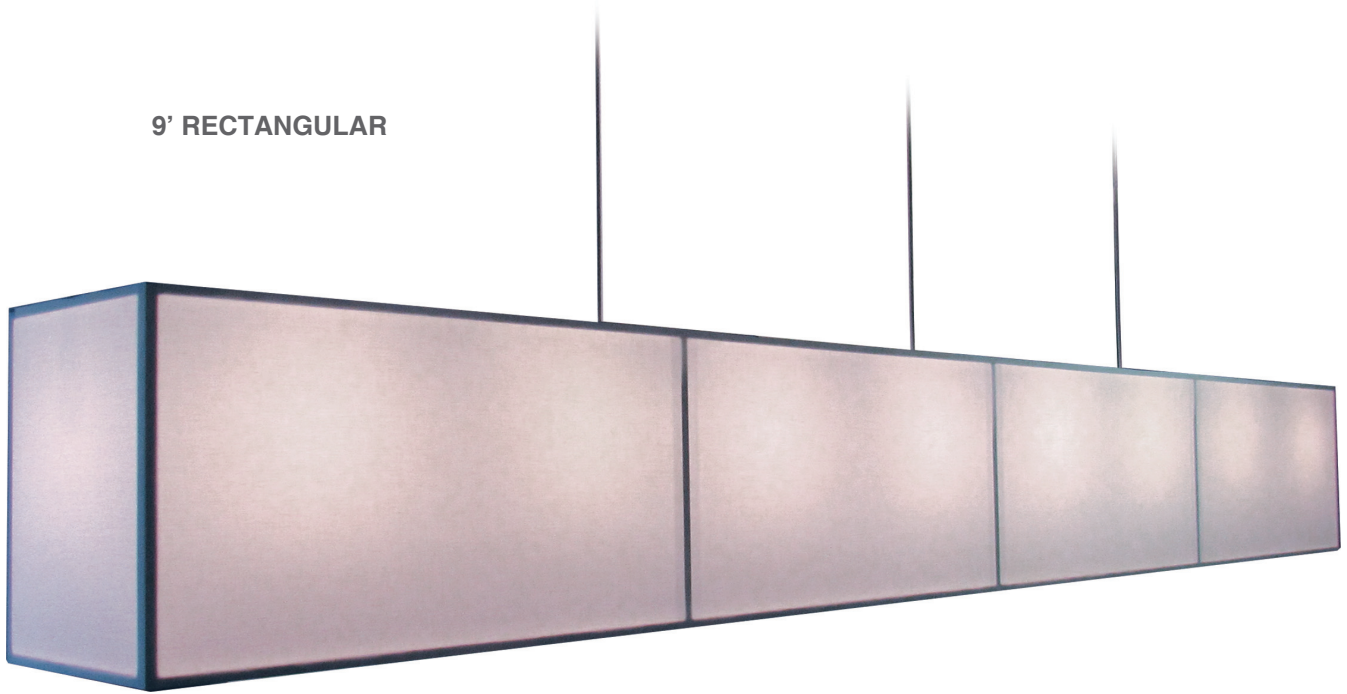

Constructed of 3/4" square aluminum tubing this fixture spans over 9 feet.

CAD Rendering

Top View

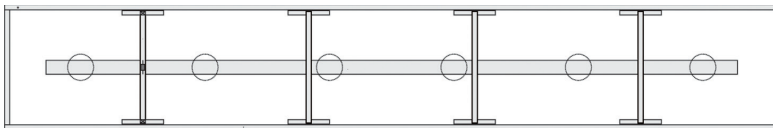

Front View

Side View

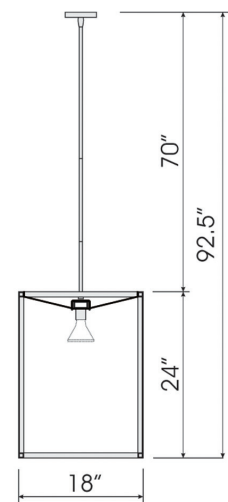
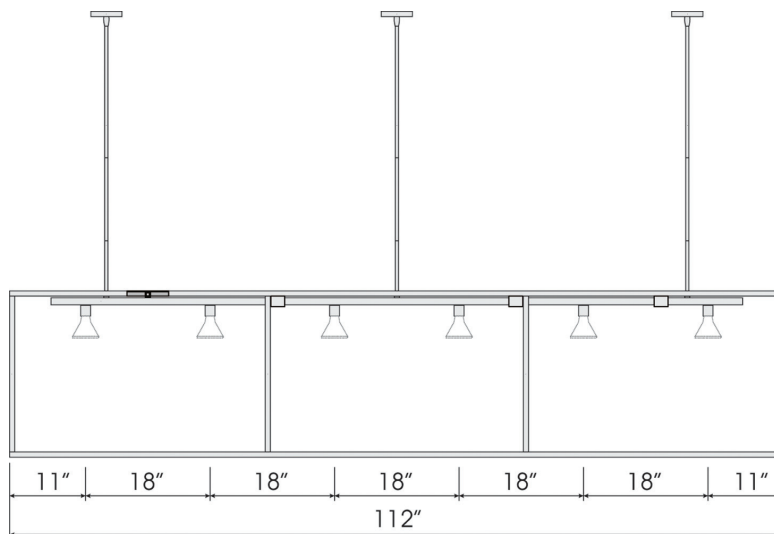

CUSTOM DESIGNS

SHADE WITHIN A SHADE RECTANGULAR

*An industry standard
for use over billiard tables,
reception desks, salad bars etc.
You name it!*

CAD
Rendering

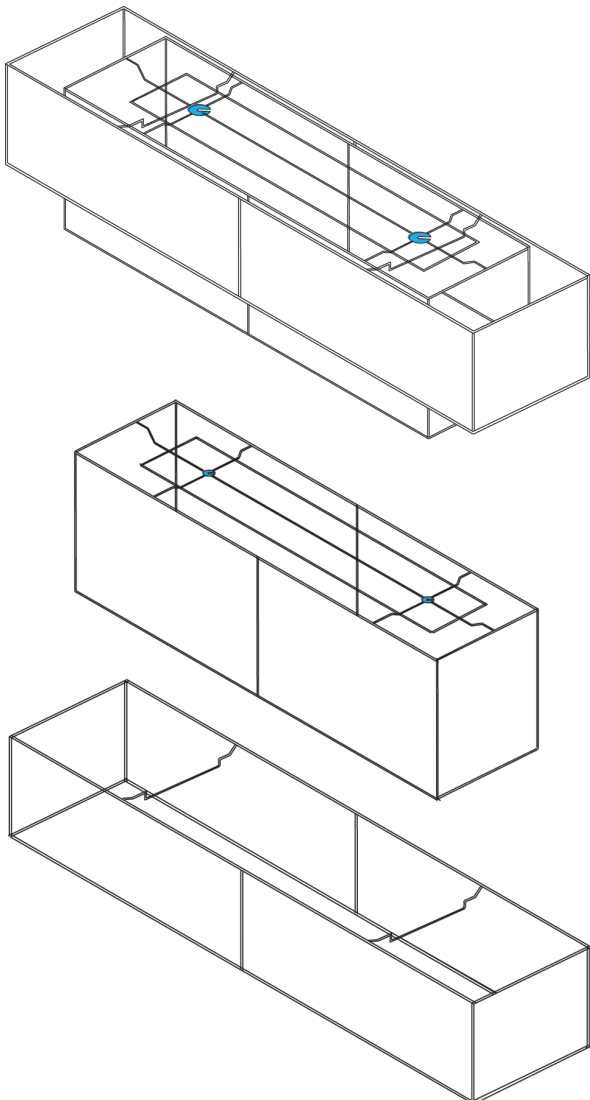
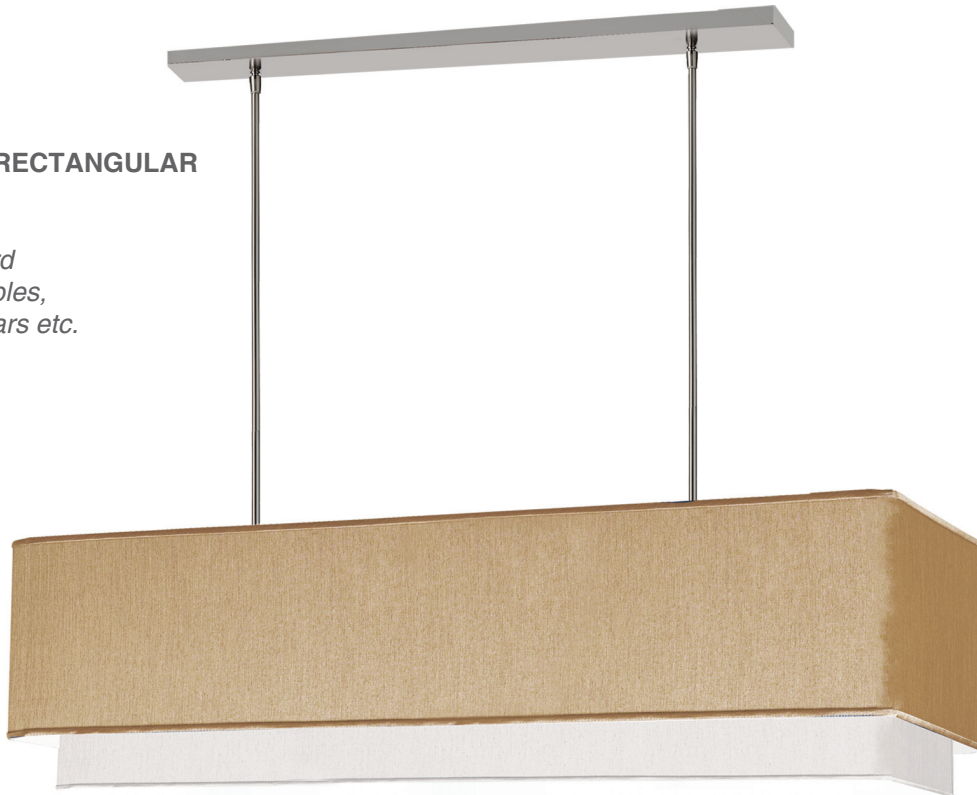

Designer's Sketch

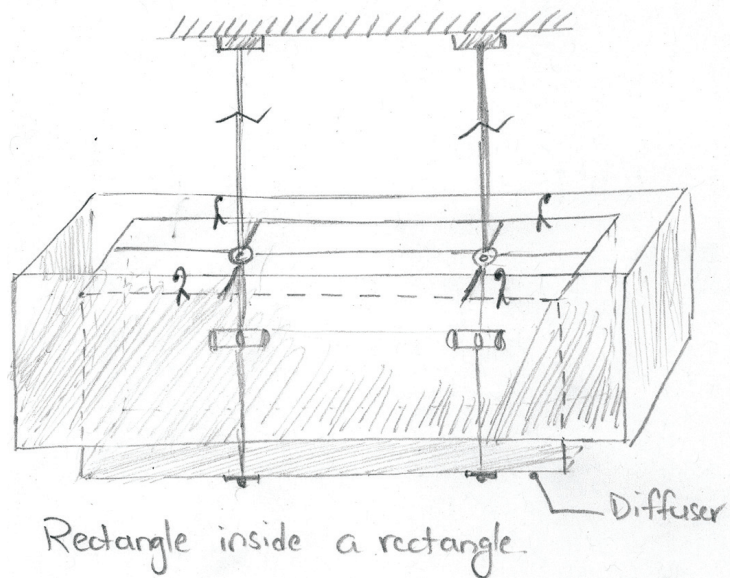

CUSTOM DESIGNS

RECTANGLES



BRIDGEWATER

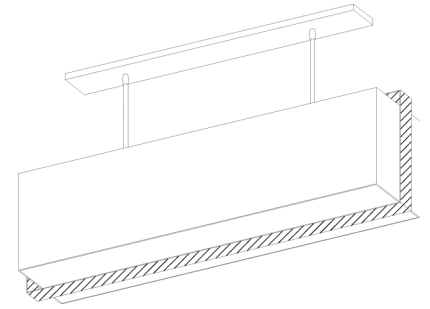

3D View



CUSTOMER'S OWN MATERIAL
(COM)



CUSTOM DESIGNS

OFFICE CEILING SOLUTIONS



Designer's Sketch

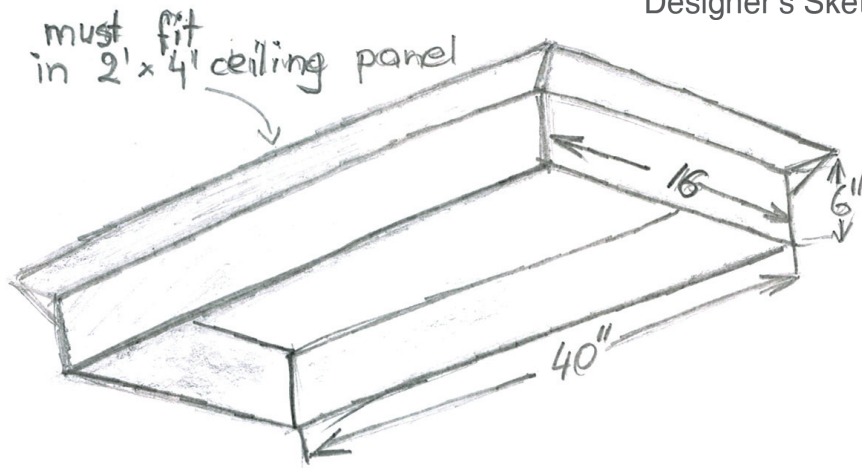

CAD Rendering

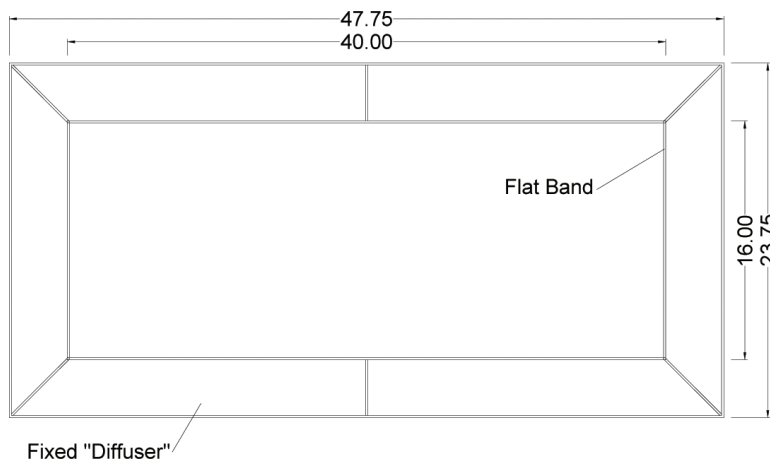

Bottom View

Front View

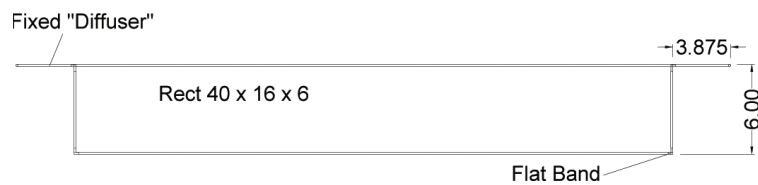

CUSTOM DESIGNS

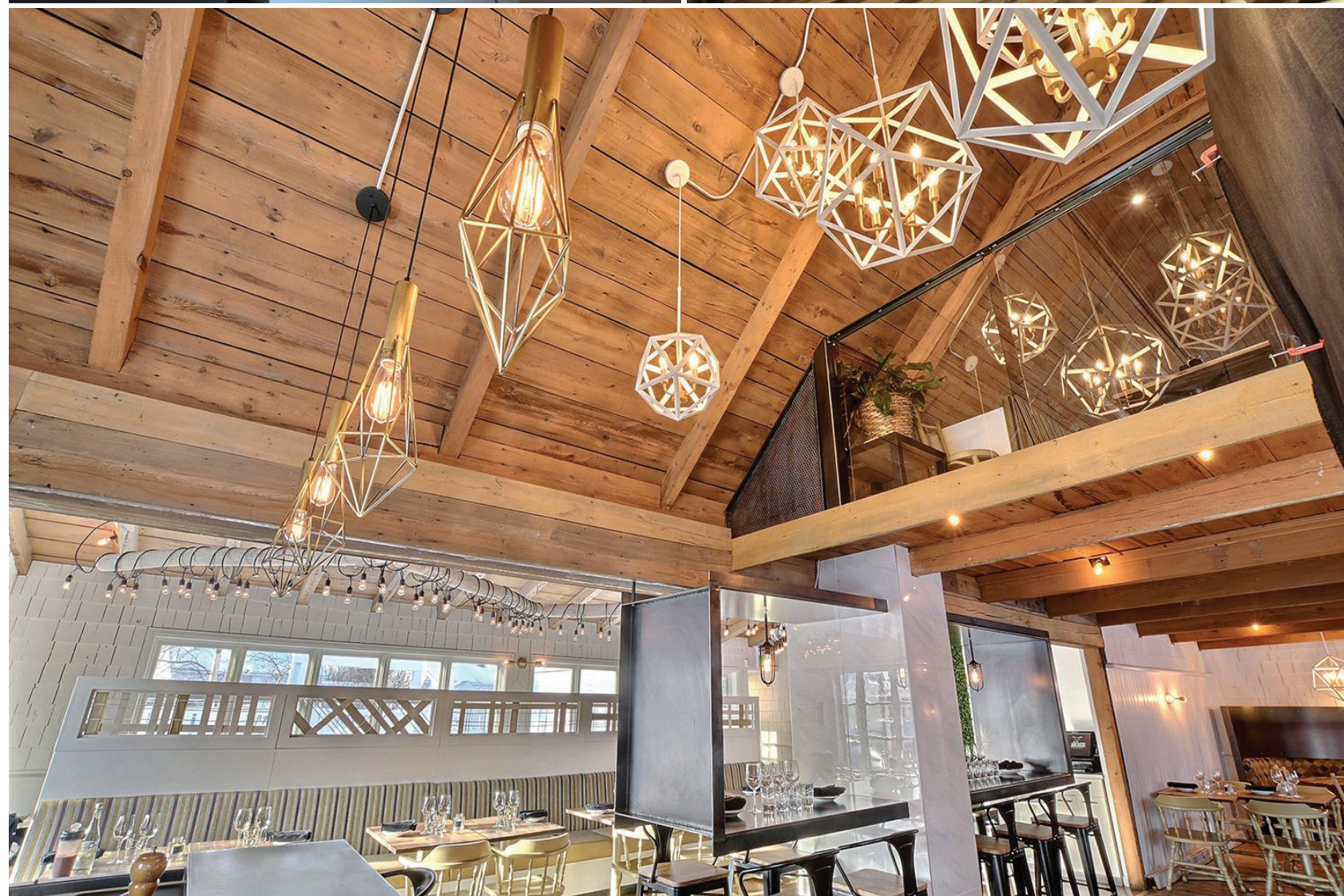

CIRQUE



CAD Rendering

Side View

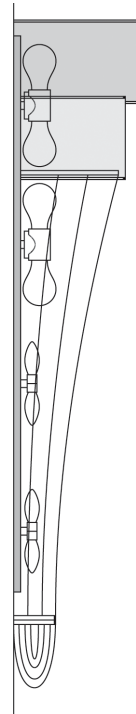

Front View

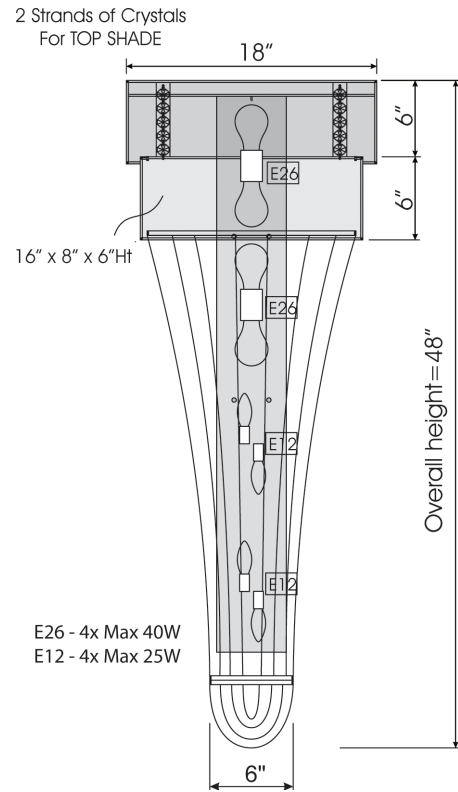

Top View

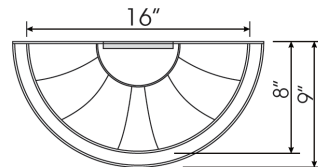

CRYSTAL ACCENTS



Designer's Sketch

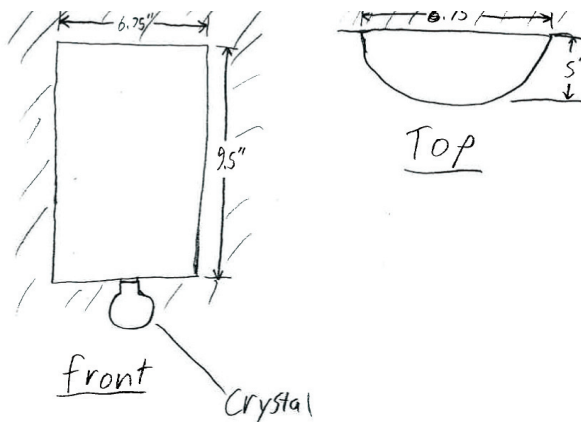

SCONCES and SHIELDS

CUT CORNER SQUARE



TAPERED RECTANGLE



SHADE WITHIN A SHADE



CRYSTAL ACCENTS - RITA



SHIELDS

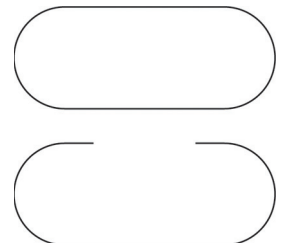
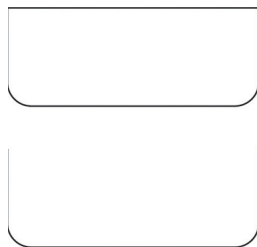
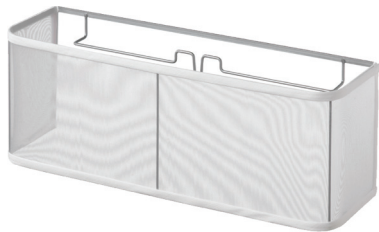
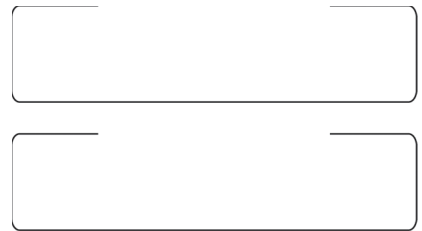

CUSTOM DESIGNS

Brush Brass Finish



Oil Rubbed Bronze

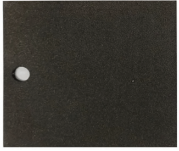

DESK LAMP

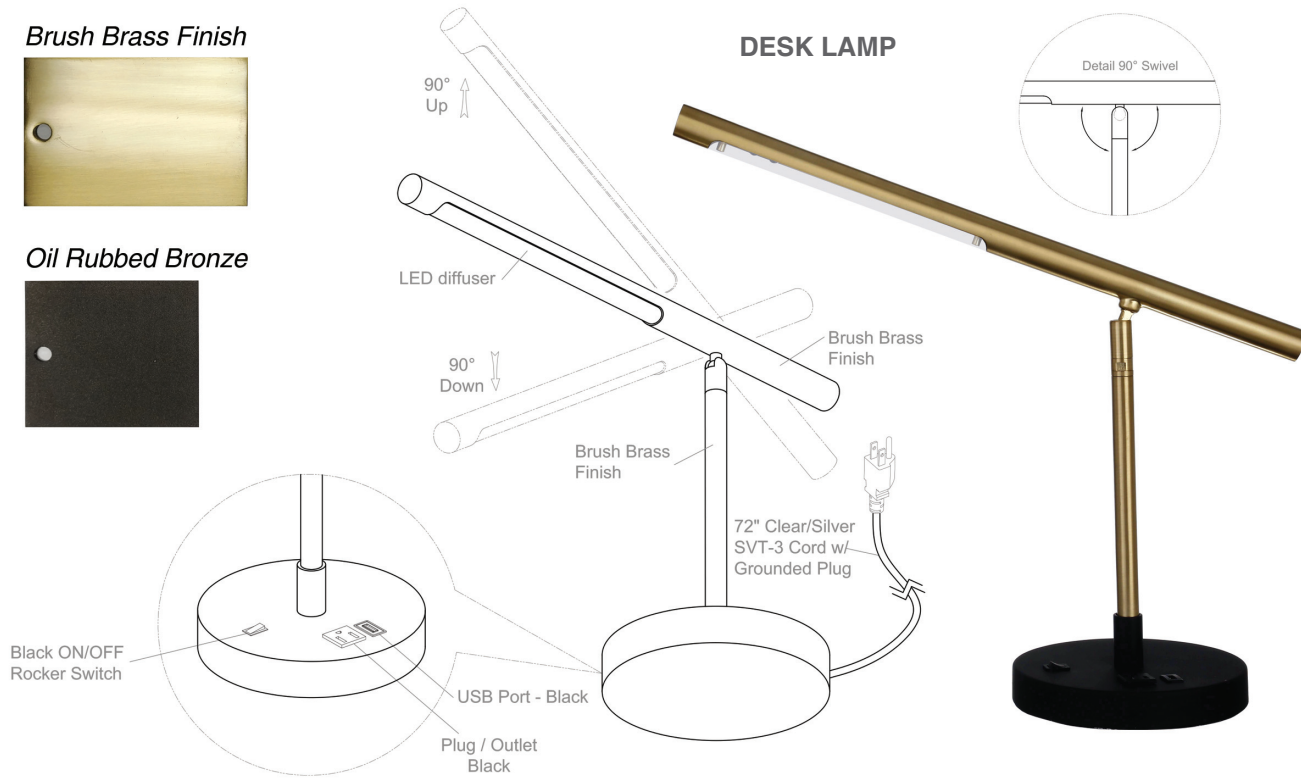
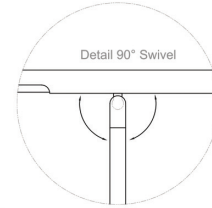

FLOOR LAMP

CUSTOM DESIGNS

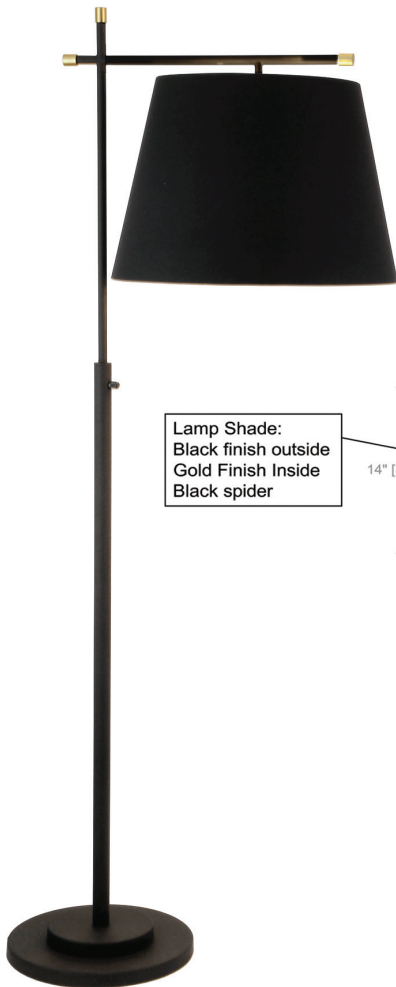

Lamp Shade:
Black finish outside
Gold Finish Inside
Black spider

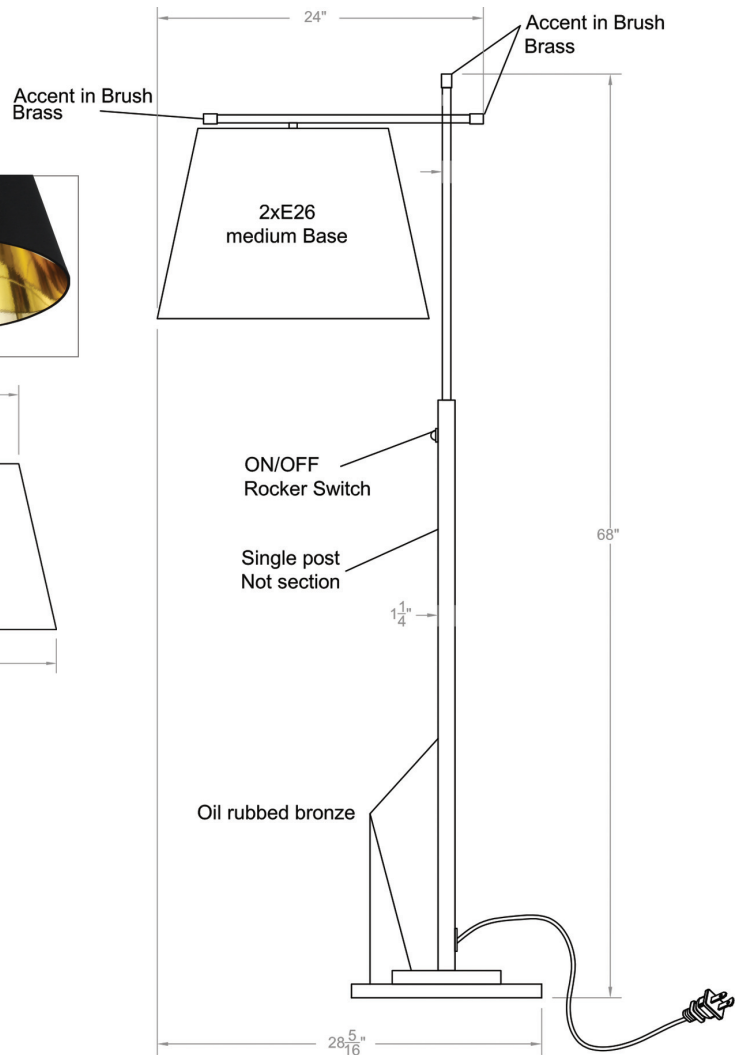
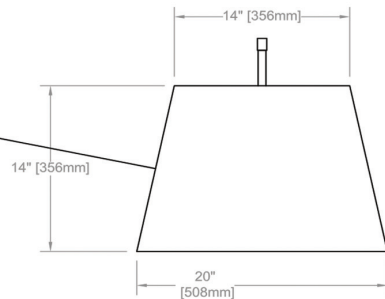

WALL LAMP

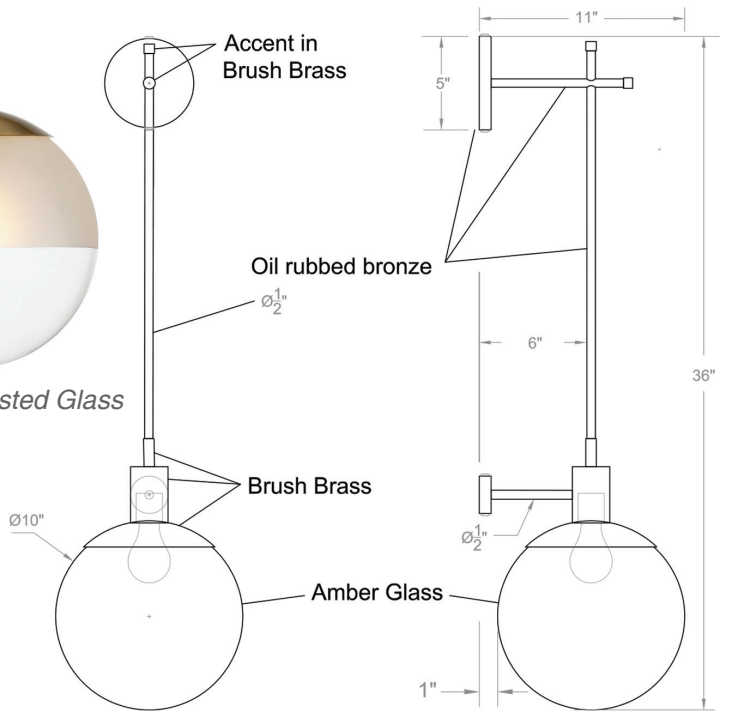

VANITY LIGHT

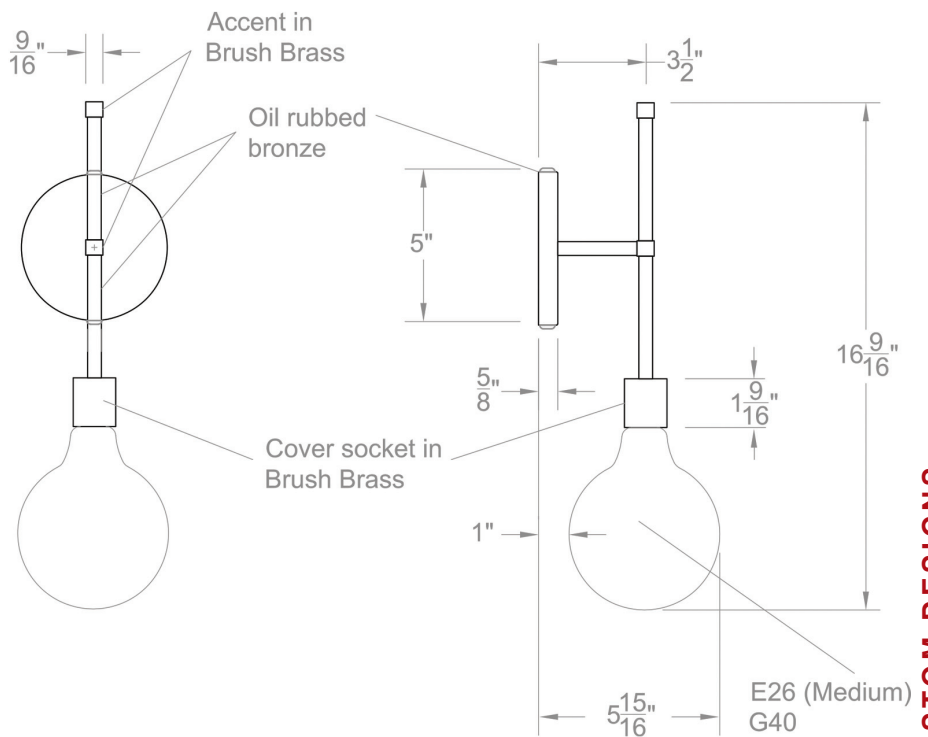

CUSTOM DESIGNS

1 LIGHT WALL SCONCE



2 LIGHT WALL SCONCE

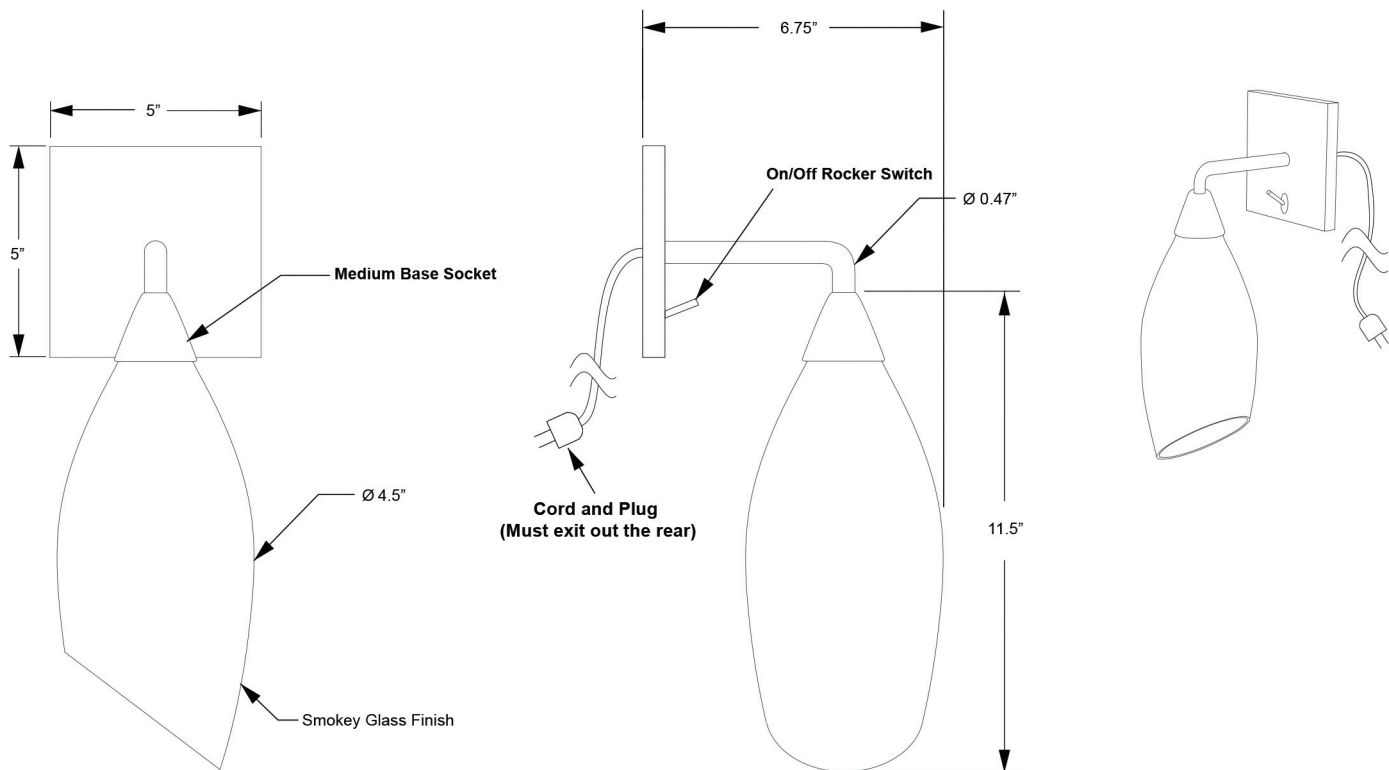
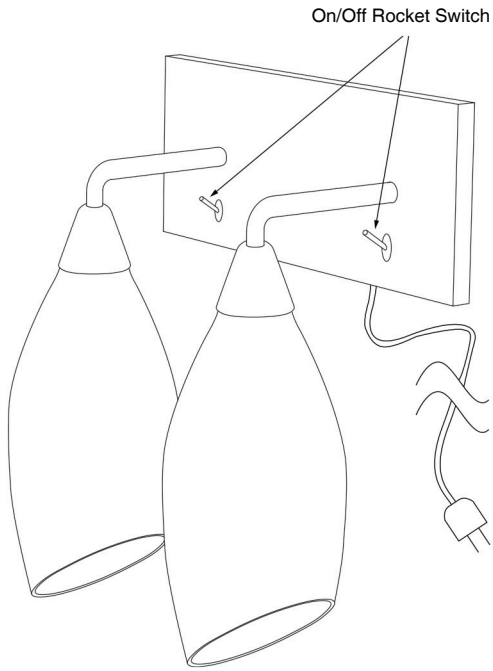

CUSTOM DESIGNS

ARTIST INSPIRATION

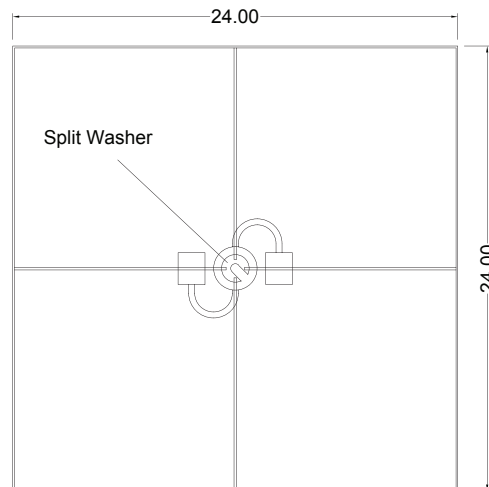
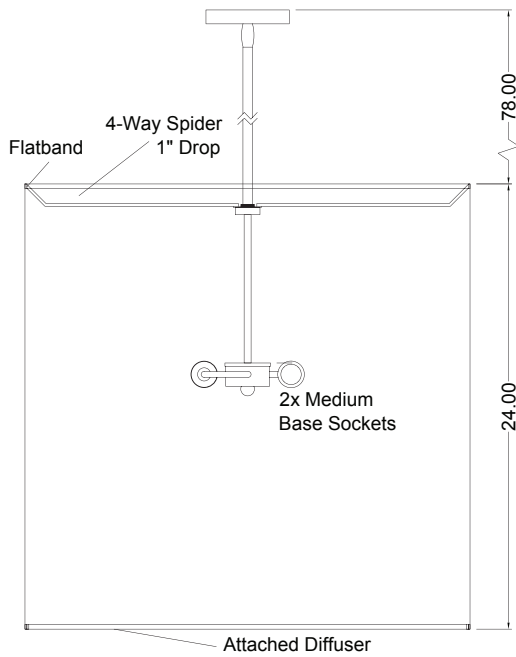
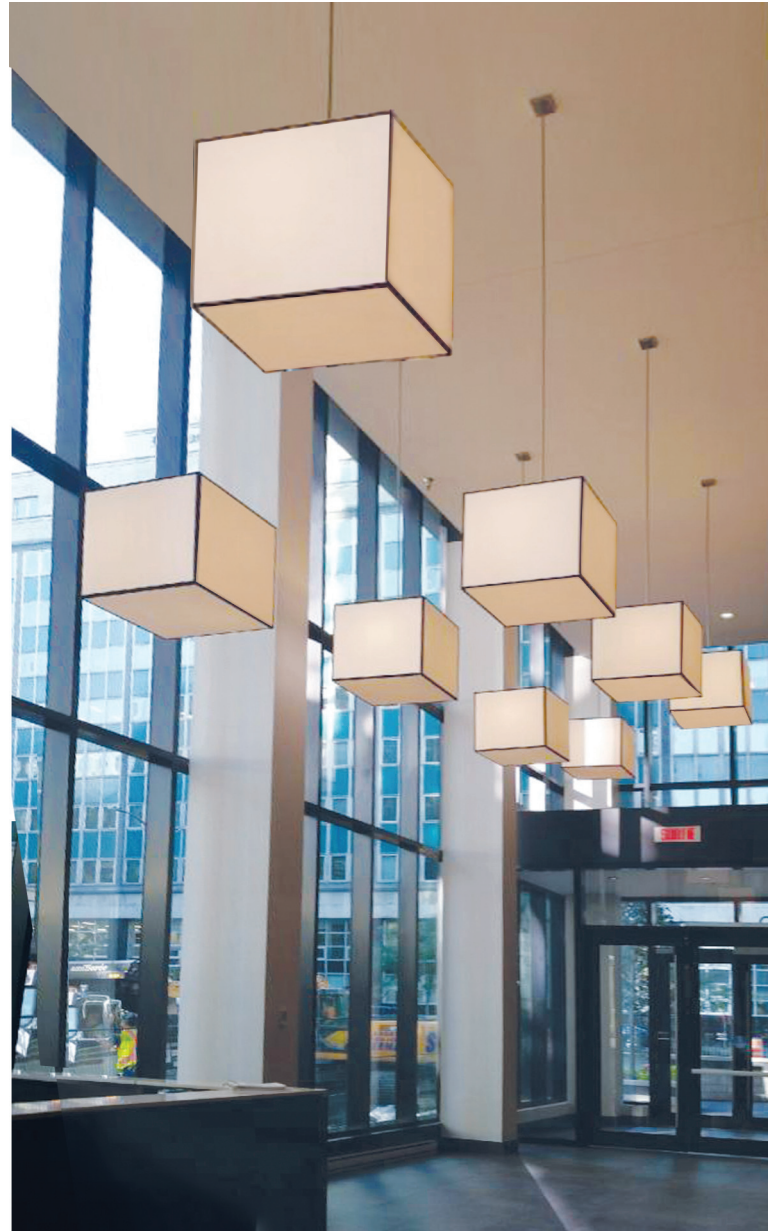

DOUBLE SWING LAMP



SINGLE SWING LAMP

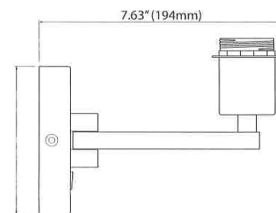
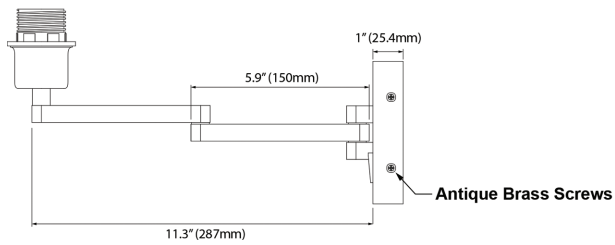
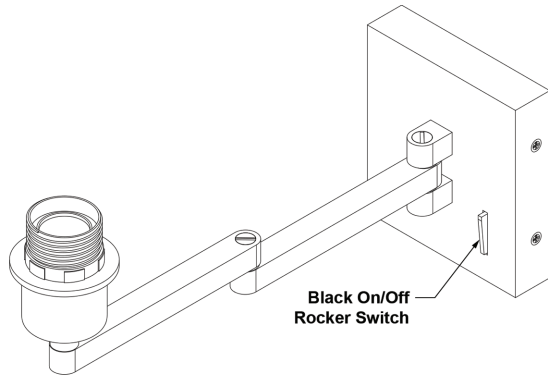

CUSTOM DESIGNS

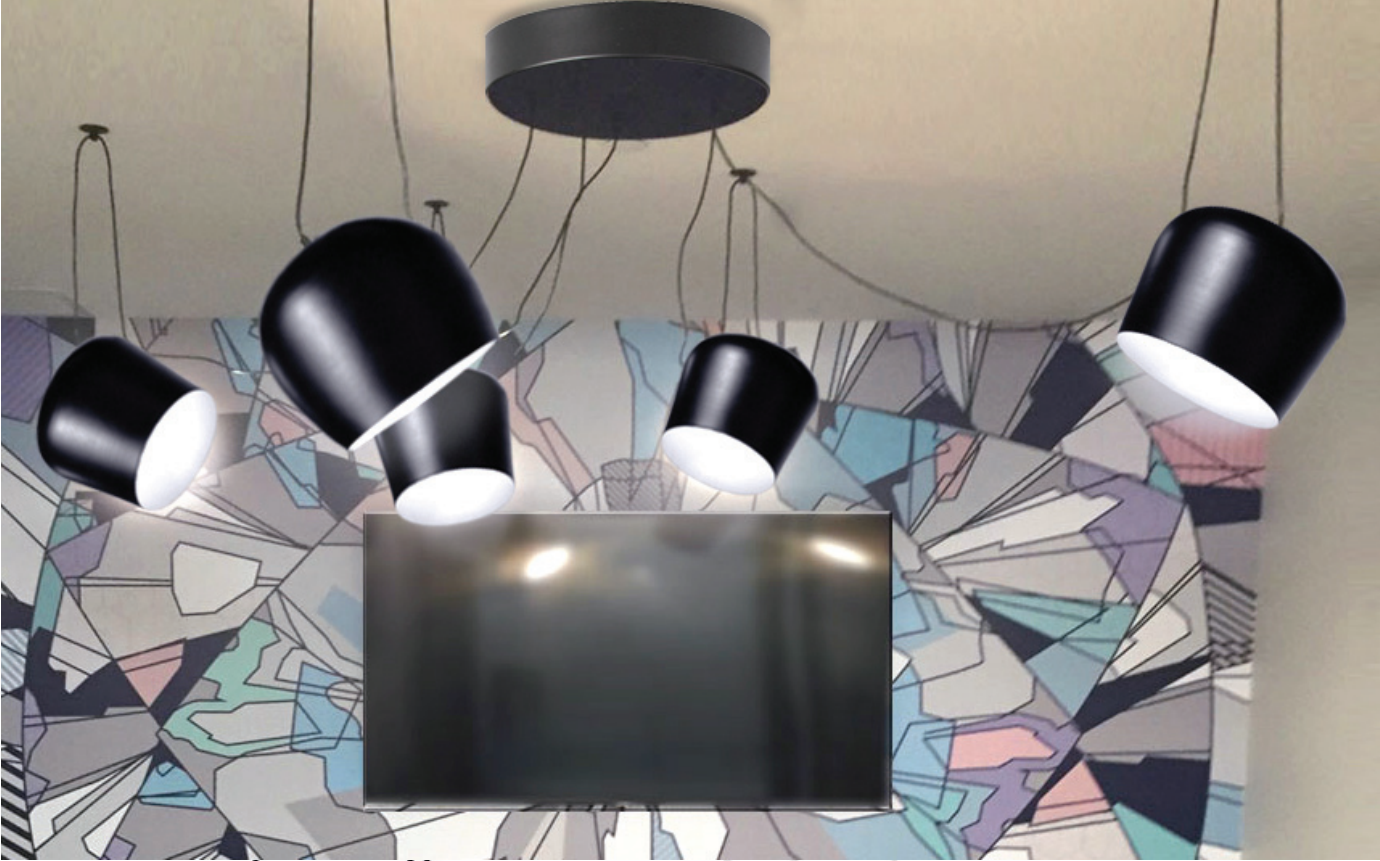

CUSTOM DESIGNS

SINGLE ARM WALL MIRROR WITH OUTLET

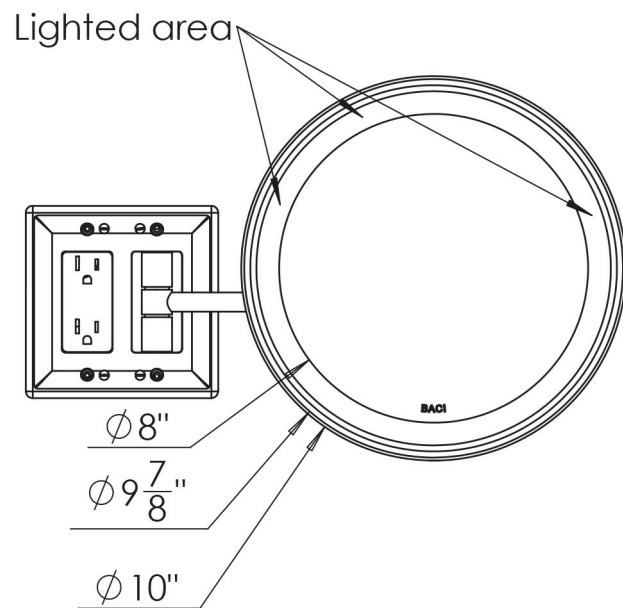
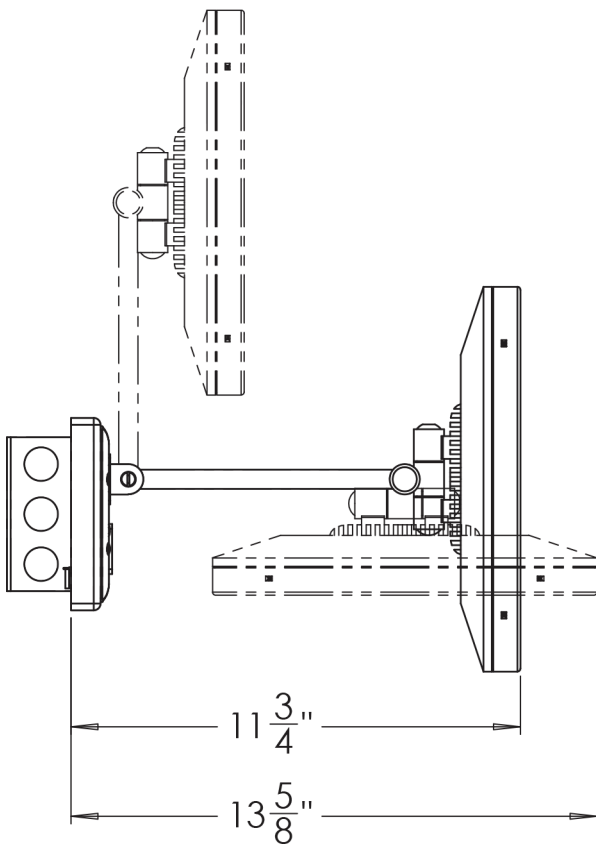
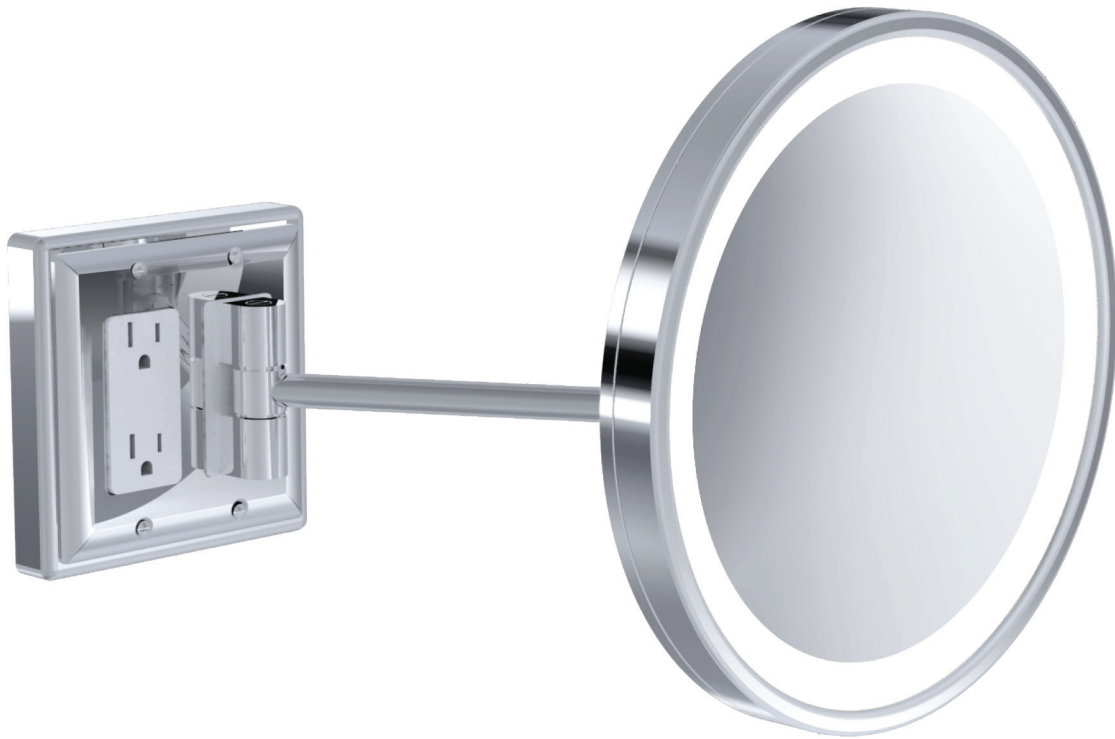

CUSTOM DESIGNS

CUSTOM LED MIRRORS



LED Lighted or Backlit Mirrors. 3000K, 80+ CRI, Dimmable, Hard-Wired

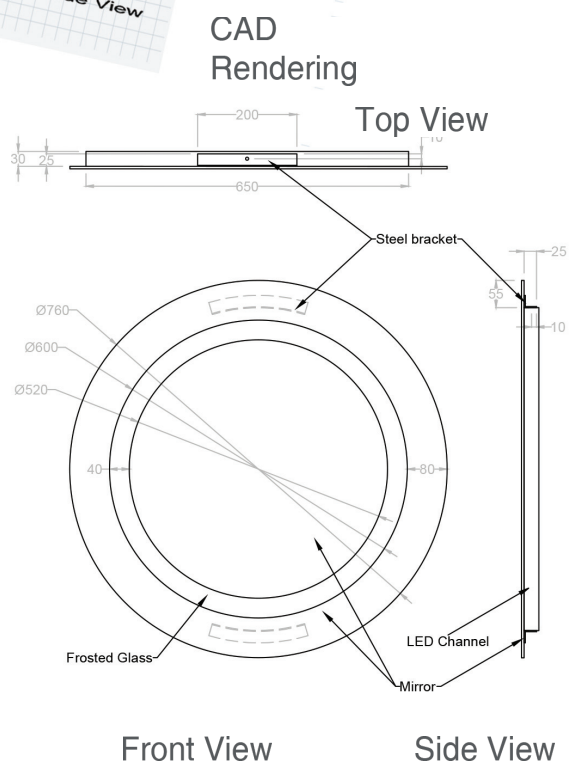
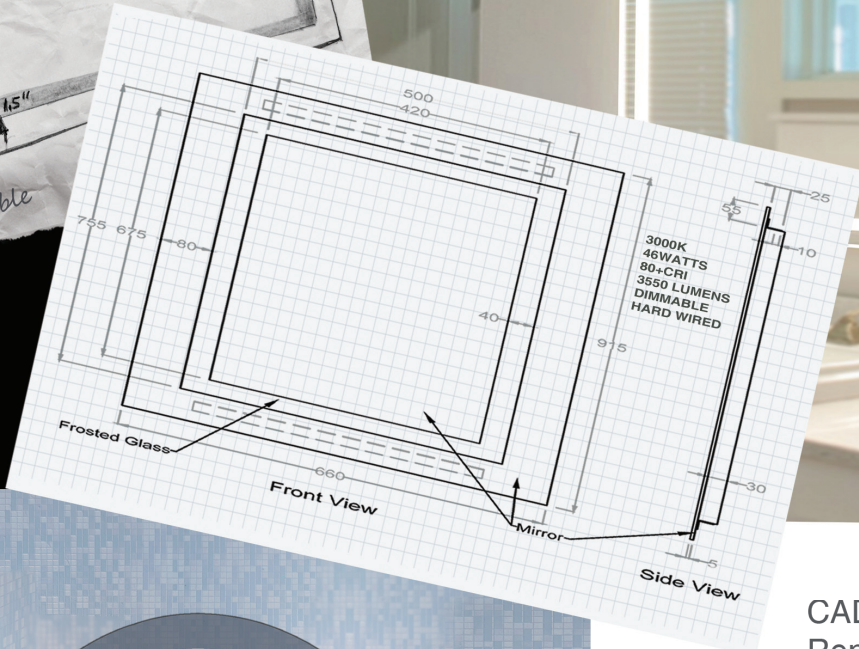

CUSTOM DESIGNS

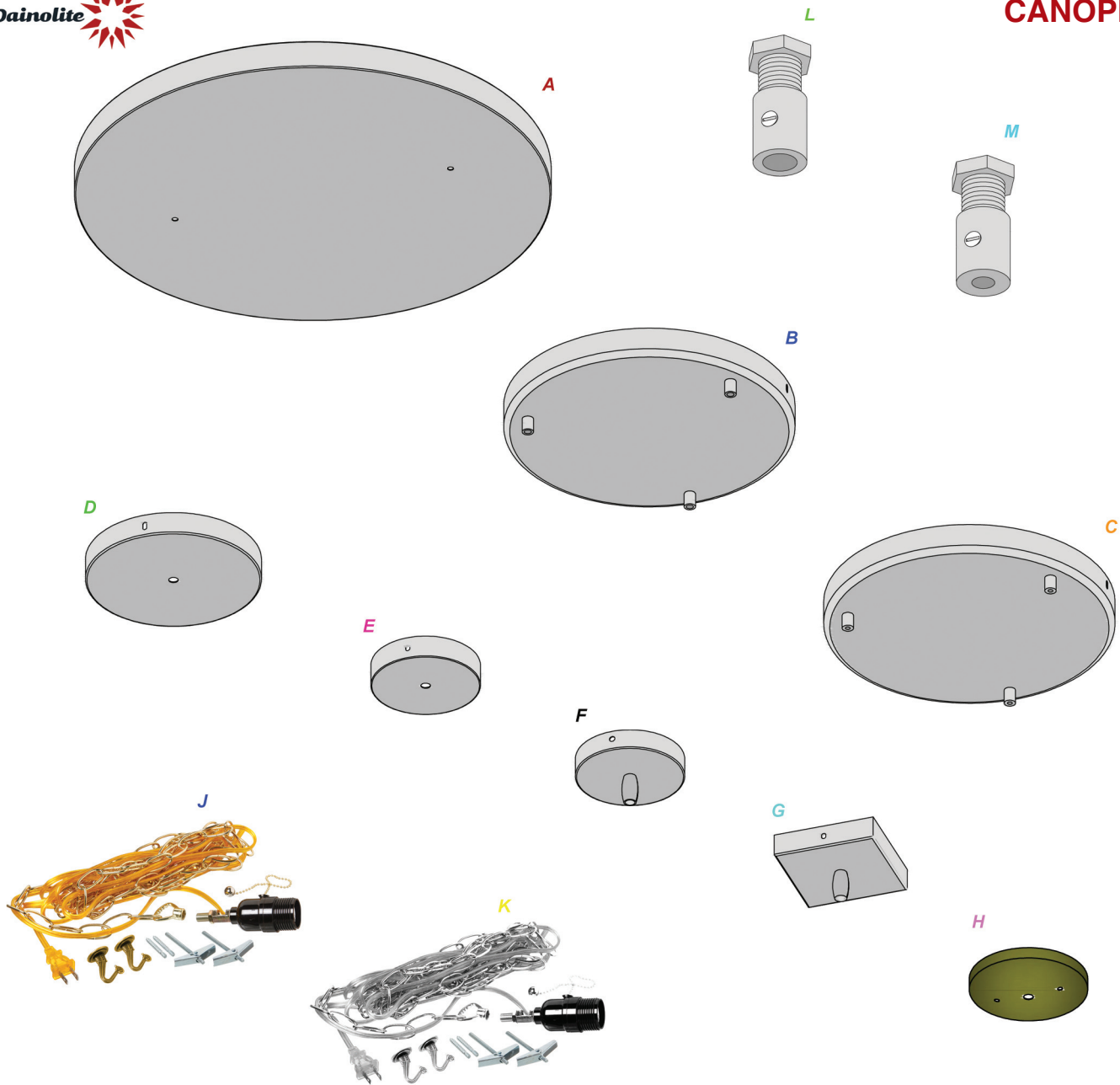

A CAN-20R

Dimensions: 1.25"H x 19.5"Ø
Satin Chrome & Polished Chrome only
2 Bottom Holes for Mounting
Single Cross Bar
3/8" Hole Location must be specified

B CPY-12R-3L-120

Dimensions: 1.25"H x 12"Ø
3 x strain relief at 10.2"Ø
Suitable for SVT-3 120Volt Cord
Side Screws for Mounting
Single Cross Bar

C CPY-12R-3L-12V

Dimensions: 1.25"H x 12"Ø
3 x strain relief at 10.2"Ø
Suitable for 12Volt Cord
Side Screws for Mounting
Single Cross Bar

D CANOPY 8

Dimensions: 1"H x 7.25"Ø
3/8" Center Hole
Side Screws for Mounting
Single Cross Bar

E CANOPY4-38

Dimensions: 1"H x 43/8"Ø
Center Hole 3/8"Ø
Side Screws for Mounting
Single Cross Bar

F CPY4R

Dimensions: 7/8"H x 4 3/8"Ø
C/w swivel, 1/8" IP Thread
Side Screws for Mounting
Single Cross Bar

G CPY 4SQ

Dimensions: 1"H x 43/8"SQ
C/w swivel, 1/8" IP Thread
Side Screws for Mounting
Double Cross Bar

H CANOPY4-78-AB

Antique Brass only
Dimensions: 7/8"H x 4 7/8"Ø
Center Hole 3/8"Ø
2 Bottom Holes for Mounting
Single Cross Bar

J SLK20-PB - Polished Brass

Swag Lamp Kit
20 feet (610cm) SPT-2 cord with molded plug and 15 feet (457cm) 11 gauge chain
Two swag hooks
Bakelite socket with pull-chain switch for use with max. 100W bulb
Socket already pre-wired

**K SLK20-PC - Polished Chrome
SLK20-WH - White**

L BUSH0012

12 Volt Canopy Strain Relief

M BUSH0120

120 Volt Strain Relief

CANOPIES



All canopies and metal stems are available in Satin Chrome, Oil Brushed Bronze and Polished Chrome finishes, unless specified. Specify finish when ordering (OBB, PC or SC).

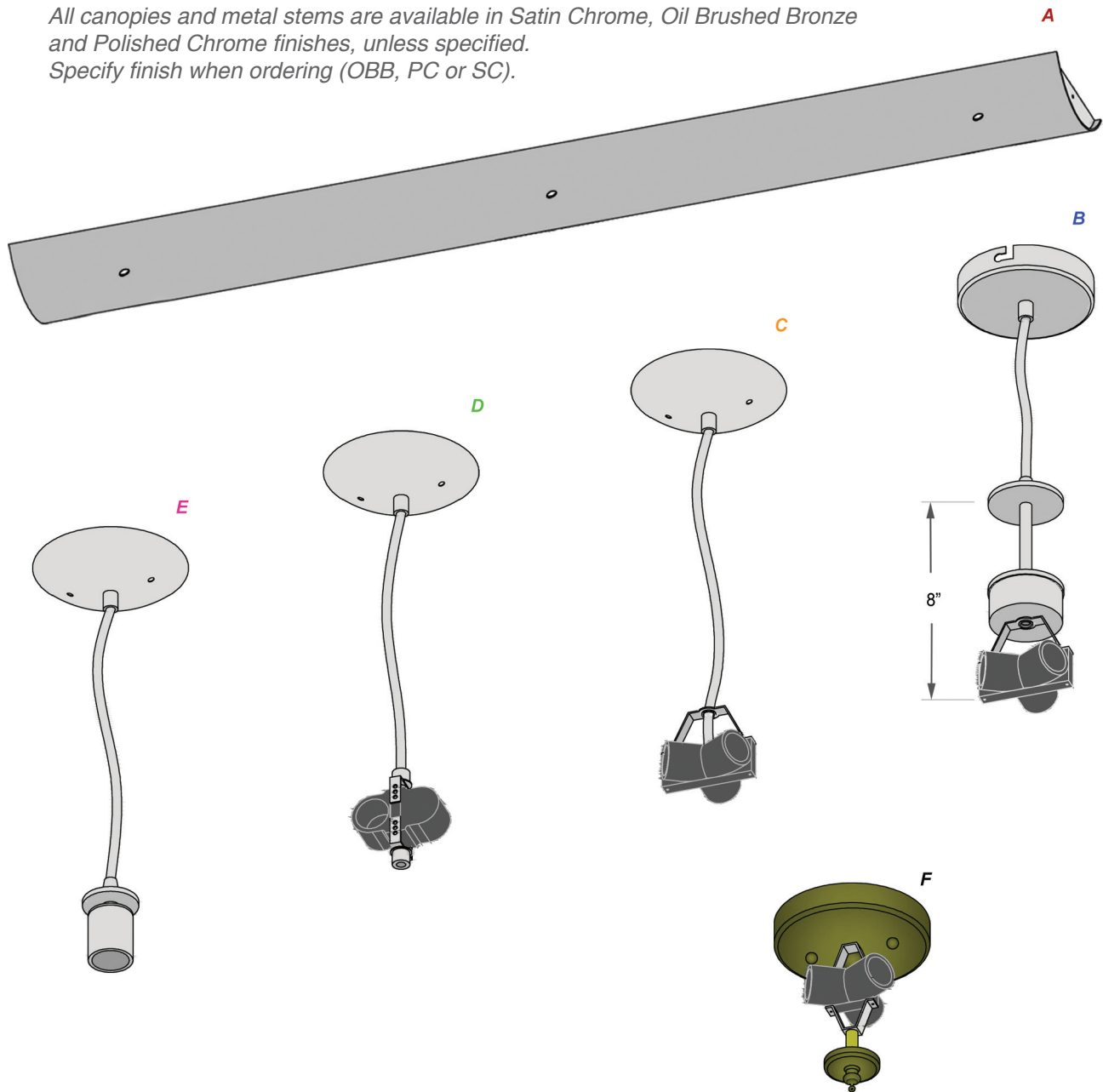

A CAN-3LT-35L
 Canopy:
 1.25"H x 34.5"L x 4.25"D
 3 x 3/8" Holes, 14.5" apart
 End Screws for Mounting

B CPY-DBL-3
 Polished Chrome & Satin Chrome only
 Canopy: 7/8"H x 43/8"Ø
 3 x E26 Sockets
 4' Clear/Silver SVT-3 Wire
 Side Screws for Mounting
 Single Cross Bar

C CPY-478-3
 Polished Chrome and Satin Chrome only
 Canopy: 1"H x 5"Ø
 3 x E26 Sockets
 4' Clear/Silver SVT-3 Wire
 Bottom Screws for Mounting
 Single Cross Bar

D CPY-478-2
 Polished Chrome and Satin Chrome only
 Canopy: 1"H x 5"Ø
 2 x E26 Sockets
 4' Clear/Silver SVT-3 Wire
 Bottom Screws for Mounting
 Single Cross Bar

E CPY-DBL-1
 Polished Chrome & Satin Chrome only
 Canopy: 1"H x 5"Ø
 1 x E26 Socket
 4' Clear/Silver SVT-3 Wire
 Bottom Screws for Mounting

F CPY-42-3-AB
 Antigue Brass only
 Canopy: 7/8"H x 5"Ø
 3 x E26 Sockets
 C/w 1.75" Check Plate and Finial
 Bottom Screws for Mounting

CUSTOM DESIGNS

CANOPIES AND ROD

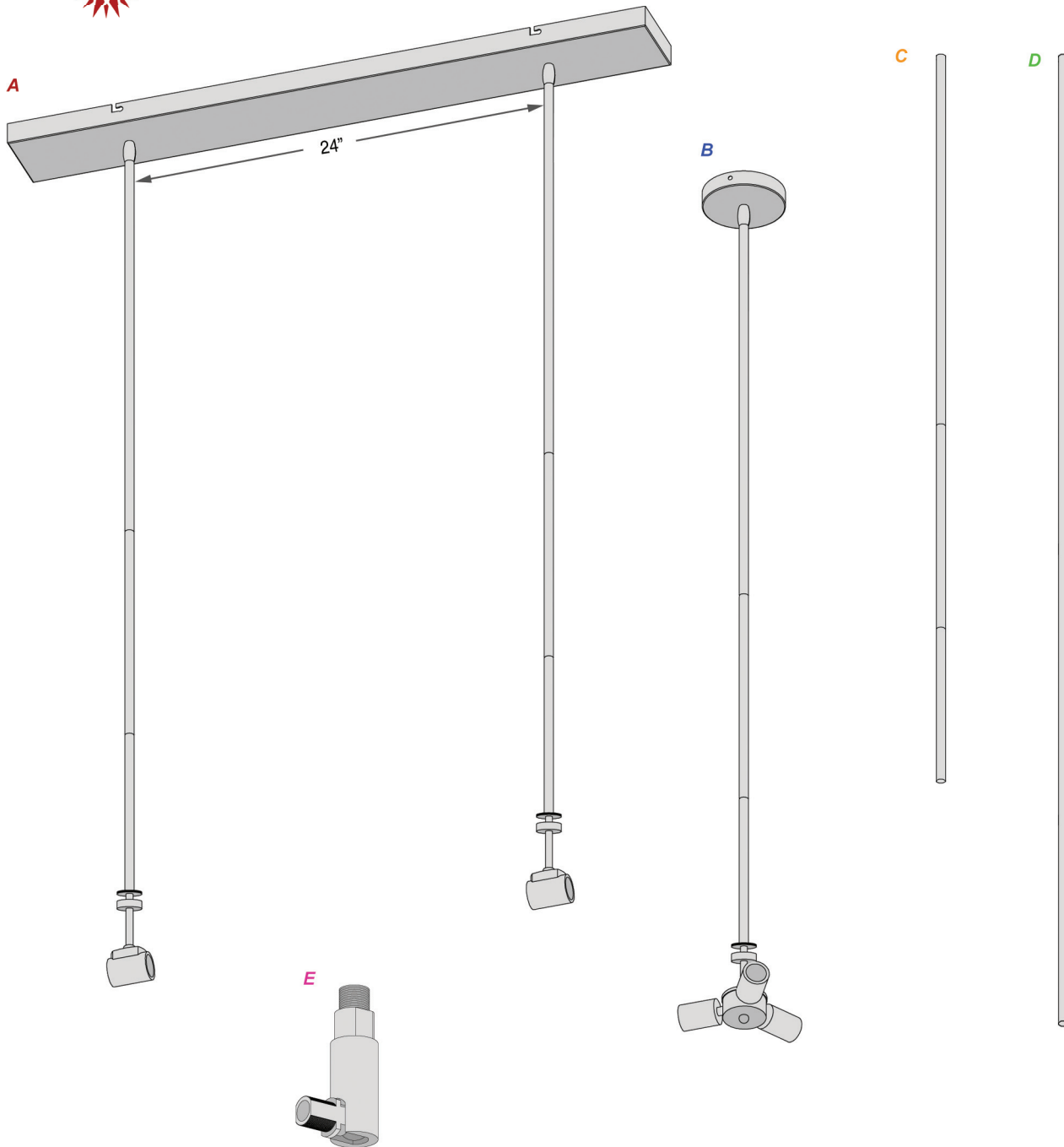

CUSTOM DESIGNS

A CANOPY-37-OBB
 Oil Brushed Bronze
 Canopy:
 1.25"H x 36.5"L x 4.25"D
 4 x E26 Sockets
 2 Swivels
 2 Fractional Rod Sets: 8"+11"+20"
 4' Wire
 Side Screws for Mounting

CANOPY-37-PC
 Polished Chrome
CANOPY-37-SC
 Satin Chrome

B CANOPY4R-OBB
 Oil Brushed Bronze
 Canopy: 7/8"H x 43/8"Ø
 3 x E26 Sockets
 Hang Straight Swivel
 Fractional Rod Set: 8"+11"+20"
 4' Wire
 Side Screws for Mounting
 Single Cross Bar

CANOPY4R-PC
 Polished Chrome
CANOPY4R-SC
 Satin Chrome

C 532-STEM-OBB
 Oil Brushed Bronze
 3 Piece Fractional Rod Set
 8"+11"+20" Rods
 3/8" Diameter
 1/8-27 Inside Thread

532-STEM-PC
 Polished Chrome

532-STEM-SC
 Satin Chrome

D 7052-STEM-OBB
 Oil Brushed Bronze
 3 Piece Fractional Rod Set
 52" Rod
 3/8" Diameter
 1/8-27 Inside Thread

7052-STEM-PC
 Polished Chrome

7052-STEM-SC
 Satin Chrome

E SWIV-90-OBB
 Oil Brushed Bronze
 Thread is 1/8 IP
 90 degree swivel for
 ceiling with more than
 15 degree slope.

SWIV-90-PC
 Polished Chrome

SWIV-90-SC
 Satin Chrome

PARTS

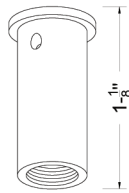

CB-PC
Base for cable gripper when mounting on ceiling. Polished Chrome finish. Use with CGR-PC

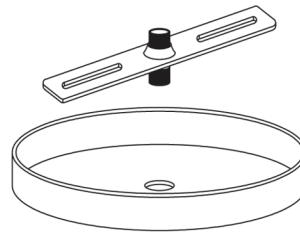

NP-CGR
Non powered cable grip assembly. Includes 4" heavy duty cross bar. 4.5" White canopy. One CGR-PC One GR-NUT One CB-PC 72" - 1/16 Aircraft cable with die cast end.

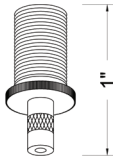

CGR-PC
Aircraft cable gripper for 1/16 and 3/64 Aircraft cable Use with CB-PC or GR-NUT



GR-NUT
1/4 IP For use with CGR-PC

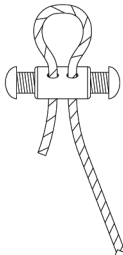

CL-1/16
Cable loop / stopper sleeve with set screws. For 1/16" or 3/64" cable. Adds measure of safety to any heavy system.

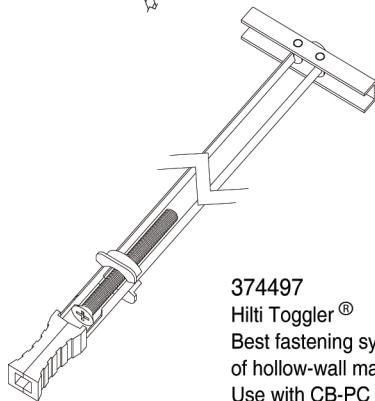

374497
Hilti Toggler® Best fastening system for wide range of hollow-wall materials. Use with CB-PC Holds up to 50 pounds.

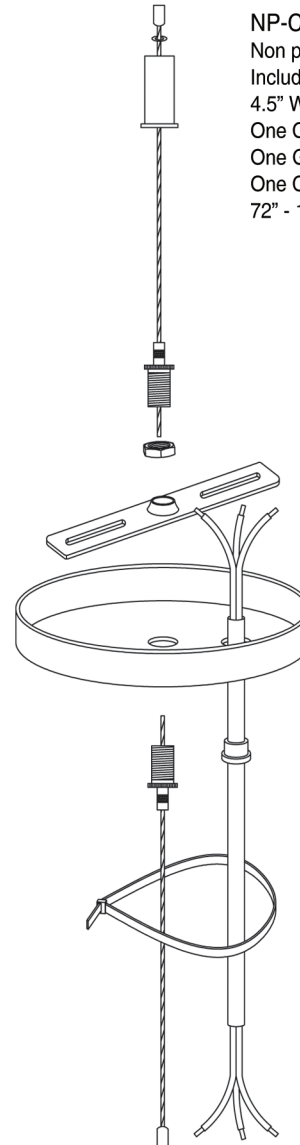

POW-CGR
Powered canopy with cable grip assembly. Includes 4" heavy duty cross bar. 4.5" White canopy. One CGR-PC 72" - 1/16 Aircraft cable with die cast end. One strain relief bushing for SVT-3 cord.

SVT-3/FT
White, black or clear. Power cord (not included). Can be purchased separately. 3 White cable ties for wire management.

LIGHTING SUSPENSION SYSTEMS

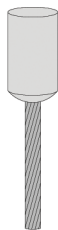

Minimum break strength with cable gripper 165 lbs.

Die Cast End Stop

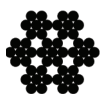

7 x 7 Wire Cross Section

Cable, 1/16" (16mm) with fuse cut and die cast end			
Model	Cross Section	Material	Length
ACC - 1/16 -72-SS	7 x 7	Stainless Steel	1/16" x 72" with stop
ACC - 1/16 -100-SS	7 x 7	Stainless Steel	1/16" x 100" with stop
ACC - 1/16 -144-SS	7 x 7	Stainless Steel	1/16" x 144" with stop
ACC - 1/16 -150-SS	7 x 7	Stainless Steel	1/16" x 150" with stop
ACC - 1/16 -156-SS	7 x 7	Stainless Steel	1/16" x 156" with stop
ACC - 1/16 -300-SS	7 x 7	Stainless Steel	1/16" x 300" with stop
ACC - 1/16 -SS	7 x 7	Stainless Steel	1/16" Sold by Ft. No stop
ACC - 3/64-SS	7 x 7	Stainless Steel	3/64" Sold by Ft. No stop
ACC - 3/64 -36-SS	7 x 7	Stainless Steel	3/16" x 36" with stop

CUSTOM DESIGNS

NO.	NAME	COLOUR	NO.	NAME	COLOUR	NO.	NAME	COLOUR
130F	GINA FLAT	WHITE	720	ITALIAN LINEN	CREAM	001	LINING	WHITE
131F	GINA FLAT	IVORY	721	ITALIAN LINEN	BEIGE	043*	LINDA SHIRRED PLEATS	BOTTLE GREEN
143*	LINDA SHIRRED PLEATS	BOTTLE GREEN	725*	BARONESS	CHOC/BROWN	055*	LINDA SHIRRED PLEATS	TEAL
155*	LINDA SHIRRED PLEATS	TEAL	728*	BURL	NATURAL	059*	LINDA SHIRRED PLEATS	BONE
159*	LINDA SHIRRED PLEATS	BONE	730*	GRANITE	NATURAL	062*	LINDA SHIRRED PLEATS	DUSTY ROSE
159F	LINDA FLAT	BONE	731	SANDSTONE	CREAM	066*	LINDA SHIRRED PLEATS	BLACK
162*	LINDA SHIRRED PLEATS	DUSTY ROSE	737*	BUTTERFLY	CREAM	091*	LINDA SHIRRED PLEATS	BURGUNDY
162F	LINDA FLAT	DUSTY ROSE	753*	RAME PAPER	WHITE	095*	LINDA SHIRRED PLEATS	WHITE
163F*	LINDA FLAT	STONE BLUE	759*	BASKET	TAUPE	098*	LINDA SHIRRED PLEATS	EGGSHELL
166*	LINDA SHIRRED PLEATS	BLACK	760	BURLAP	WHITE	106	ORGANZA	BRONZE
166F	LINDA FLAT	BLACK	761	BURLAP	NATURAL	107	ORGANZA	RUST
189F*	LINDA FLAT	HUNTER GREEN	762*	AMERICAN FLAG		109	ORGANZA	RED
191*	LINDA SHIRRED PLEATS	BURGUNDY	769*	SHADOWBOX	WH.CHOC.	110	ORGANZA	CHOC. BROWN
195*	LINDA SHIRRED PLEATS	WHITE	770	BLACK LIZAGATOR	BLACK/WHITE	111	ORGANZA	GOLD
195F	LINDA FLAT	WHITE	771	ICE	WHITE	114	ORGANZA	SILVER
198*	LINDA SHIRRED PLEATS	EGGSHELL	772	ICE	RED	115*	ORGANZA	BLACK
198F	LINDA FLAT	EGGSHELL	775*	DAUPHINE	HUNTER GREEN	117*	ORGANZA	OYSTER
2400	LAMINATED CAMELOT	MILANO WHITE	778	ICE	GREEN	118	ORGANZA	CREAM
2405	LAMINATED CAMELOT	CREAM	779	ICE	BLUE	119	ORGANZA	WHITE
2406	LAMINATED CAMELOT	BLACK	781*	ICE	PURPLE	120	SHANTUNG	BEIGE
2407	LAMINATED CAMELOT	TAUPE	783*	WORLD MAP		121	SHANTUNG	WHITE
2423	LAMINATED CAMELOT	GREY	785*	BANANA KINTOKE	NATURAL	122	SHANTUNG	EGGSHELL
399	STYRENE	WHITE	788*	JEWEL TONES	GREY	123	BARONESS	BLACK/GLD LINING
3113*	WHITE STYRENE CAMELOT	GREY	790	JEWEL TONES	WHITE	125	BARONESS	BROWN / WHITE
4149	USE 791		791	JEWEL TONES	IVORY	130	GINA	WHITE
4150	DIANA	CREAM	792	JEWEL TONES	PINK	131*	GINA	IVORY
4151	DIANA	TAN	795	JEWEL TONES	RED	134	SILK GLOW	STEEL
634	SILK GLOW	PLATINUM on SV	796*	JEWEL TONES	NAVY BLUE	135	ITALIAN LINEN	CREAM
637	SILK GLOW	PEBBLE on SV	797	JEWEL TONES	BLACK	136	ITALIAN LINEN	BEIGE
642	SILK GLOW	BRUSHED GLD on GLD	798*	WICKER	TWO TONE	138	SILK GLOW	LATTE
690	JEWEL TONES	WHITE/DULCOAT	799*	WICKER	NATURAL	139*	SILK GLOW	CREAM
691	JEWEL TONES	WHITE/SILVER	809	VINYL	CLEAR	140	SILK GLOW	PEARL
692	JEWEL TONES	WHITE/GOLD	810	LAMINATED ORGANZA	CHOC.BROWN	141	SILK GLOW	GOLD
693	BARONESS WH. ON SV.	WHITE/SILVER	814	LAMNATED ORGANZA	SILVER	142	SILK GLOW	BRUSHED GOLD
695	BARONESS	IVORY	815	LAMINATED ORGANZA	BLACK	149	DIANA	WHITE
696	LINDA	ZEBRA PRINT	817	LAMINATED ORGANZA	OYSTER	150	DIANA	CREAM
697	JEWEL TONES	BLACK/SILVER	819	LAMINATED ORGANZA	WHITE	151	DIANA	TAN
698	JEWEL TONES	BLACK/GOLD	833	SILK GLOW	CELEDON	900	LYCRA	WHITE
706	BK. PARCH. ON SV/BK TAPE	BLACK/SILVER	837	SILK GLOW	PEBBLE	901	LYCRA	BLACK
707*	OIL PARCHMENT	NATURAL	838	SILK GLOW	LATTE	923	LYCRA	SILVER
708	SILVER ON WH. PARCHM.	SILVER/WHITE	839	SILK GLOW	CREAM	927	LYCRA	RED
709	DO-IT YOURSELF (PEEL&STICK)	WHITE	841	SILK GLOW	GOLD			
712	BK PARCH. ON WH/BK TAPE	BLACK/WHITE	842	SILK GLOW	BRUSHED GLD			
714	BK PARCH. ON GLD/BK TAPE	BLACK/GOLD	897	GOLD MYLAR NON WOVEN	GOLD			
718	ITALIAN LINEN	DARK TAUPE	898	SILVER MYLAR NON WOVEN	SILVER			
719	ITALIAN LINEN	WHITE	899	SILVER MYLAR	SILVER			

CUSTOM DESIGNS

*Limited quantity

FABRIC

HARDBACK



SOFTBACK



CUSTOM DESIGNS

Dainolite Ltd.
1401 Courtney Park Drive East
Mississauga, Ontario
Canada L5T 2E4
Tel: 905.564.1262
Fax: 905.564.1299

Dallas Market Center
Showroom # 4303
2100 Stemmons Freeway
Dallas, Texas
USA 75207

General inquires:
dainolite@dainolite.ca

Designers and Architects:
contractsales@dainolite.ca

www.dainolite.ca

Printed in Canada 2018
\$ 10.00



Just need to refresh an old look?
Ask for Dainolite's replacement shade catalogue.
Basic lampshades for table and floor lamps.
Bells, Drums, Empire, Softback or Hardback
shades perfect for renovation.